

Playford Corner Works

Landscape Management Scheme

DCO Requirement 14 (1) & (2)

(Applicable to Work Numbers 39 and 40)

Prepared by:	Checked by:	Approved by:
<i>John Dawkins, OPEN</i>		

Revision Summary					
Rev	Date	Prepared by	Checked by		Approved by
1	12/10/21	Kay Griffin	Phil Williamson	Rew-	Gareth Mills
2	28/01/22	John Dawkins, OPEN	Phil Williamson	Rew-	Gareth Mills
3	23/3/22	John Dawkins, OPEN	Phil Williamson	Rew-	Gareth Mills

Description of Revisions			
Rev	Page	Section	Description
1	All	All	New Document
2	All	All	Amended in accordance with comments from ESC (27/10/21)
3	All	All	Amended in accordance with comments from ESC (11/02/22)

FOR DISCHARGE

TABLE OF CONTENTS

1. INTRODUCTION AND SCOPE.....	6
1.1. Project Overview	6
1.2. Purpose and Scope.....	6
1.3. Background	7
2. ABBREVIATIONS	7
3. CONSTRUCTION DETAILS	8
3.1. Cable Works – Overview	8
3.2. Playford Corner Works	9
3.2.1. Accesses AP-X and AP-W, the Crossing Point, Access Tracks and Haul Roads	10
3.2.2. Secondary Construction Consolidation Site (Work No. 40)	10
3.2.3. Jointing Bay 12 (Work No. 39)	11
3.2.4. Cable Installation	11
3.2.5. Reinstatement	11
4. LANDSCAPE MANAGEMENT SCHEME GOVERNANCE.....	11
5. LOCAL COMMUNITY LIAISON	11
6. RELEVANT STANDARDS AND LEGISLATION	12
6.1. Applicable Standards and Good Practice	12
6.1.1. Tree and Hedgerow Protection During Construction	12
6.1.2. Tree Work by Arboriculturalists	12
6.1.3. Topsoil Handling, Stripping and Storage.....	12
6.1.4. Quality of Trees and Shrubs	12
6.1.5. Maintenance of Gardens/ Landscapes.....	12
6.1.6. Horticulture.....	12
6.1.7. Turf (if substituted for grass seeding).....	12
6.2. Relevant Legislation	12
7. PROPOSED LANDSCAPE MITIGATION WORKS.....	13
7.1. General Overview.....	13
7.2. Hedgerow Mitigation Planting.....	14
7.3. Tree and Hedgerow Protection.....	16
7.4. Grassland Re-establishment	16
7.5. Topsoil Storage Strategy	17
7.5.1. General	17
7.5.2. Stripping Topsoil and Vegetation Removal	17
7.5.3. Storage of Topsoil and Subsoil	17
7.5.4. Grass for Long-Term Topsoil Storage.....	18
7.6. Ecology	18
7.6.1. Breeding Birds	18
7.6.2. Bats.....	18

7.6.3.	Reptiles	18
7.6.4.	Other Protected or Notable Species	18
7.6.5.	Notable and Invasive Species	18
8.	IMPLEMENTATION OF PLANTING	19
8.1.	General	19
8.1.1.	Seasonal and Climatic Conditions	19
8.1.2.	Machines and Tools	19
8.1.3.	Underground Service	19
8.2.	Plant Material	19
8.2.1.	Plant Quality	19
8.2.2.	Bare Root Plants	19
8.2.1.	Seeds	20
8.2.2.	Native Hedgerow Species	20
8.2.3.	Labelling	20
8.2.4.	Substitutes	20
8.3.	Preparation for Planting	20
8.3.1.	Site Clearance	20
8.3.2.	Soil Restoration	20
8.3.3.	Cultivation	21
8.3.4.	Hedgerow Cultivation	21
8.3.5.	Sowing Grasses	21
8.4.	Planting and Seeding	21
8.4.1.	Plant Handling, Storage and Transportation	21
8.4.2.	Planting Hedgerow Transplants	21
8.4.3.	Sowing Grasses	22
8.4.4.	Watering	22
9.	MAINTENANCE OF PLANTING	22
9.1.	Aims	22
9.1.1.	Legal Obligations	23
9.1.2.	General Requirements	23
9.2.	Proposed Hedgerow Planting (HM)	24
9.3.	Improved Grassland (G1)	25
9.4.	Topsoil Storage Mix (G4)	26
9.5.	Programming of Maintenance Tasks	27
10.	REFERENCES	28
	APPENDIX 1 ARBORICULTURAL IMPACT ASSESSMENT	29
	APPENDIX 2 playford LANDSCAPE MITIGATION PLANS AND SCHEDULE	30
	APPENDIX 3 HEDGEROWS & GRASSES PLANTING SCHEDULES (EA3-LDC-CNS-BOM-IBR-000004)	31
	APPENDIX 4 FENCING DETAILS (EA3-LDC-CNS-BOM-IBR-000003)	32

APPENDIX 5 TYPICAL DETAILS FOR TREE AND HEDGEROW PROTECTIVE FENCING (EA3-LDC-CNS-DRG-IBR-000006)..... 33

FIGURES

Figure 1 Site Context Plan

FOR DISCHARGE

1. INTRODUCTION AND SCOPE

1.1. Project Overview

1. East Anglia Three Limited (EATL) was awarded a Development Consent Order (DCO) by the Secretary of State, Department of Business, Energy and Industrial Strategy (DBEIS) on 7 August 2017 for the East Anglia THREE Offshore Windfarm (EA THREE). The DCO granted consent for the development of a 1,200MW offshore windfarm and associated infrastructure and is live until 28 August 2022.
2. The DCO has now been subject to three non-material variations:
 - In March 2019 EATL submitted a non-material change application to DBEIS to amend the consent to increase the maximum generating capacity from 1,200MW to 1,400MW and to limit the maximum number of gravity base foundations to 100. In June 2019 DBEIS authorised the proposed change application and issued an Amendments Order.
 - In July 2020 EATL submitted a second non-material change application to DBEIS to amend the parameters of its offshore substations (reducing the number of these to one) and wind turbines (a decrease in the number of turbines and an increase in their hub height and rotor radius). On 15 April 2021 DBEIS authorised this proposed change application and issued an Amendments Order.
 - In August 2021 EATL submitted a third non-material change application to DBEIS to amend the consent to remove the maximum generating capacity of 1,400MW and to amend the parameters of its wind turbines (a decrease in the number of turbines and an increase in their hub height and rotor radius). The application is currently in the consultation phase.
3. The onshore construction works associated with EA THREE will have a capacity of 1,400MW and transmission connection of 1,320MW. The construction works will be spread across a 37km corridor between the Suffolk coast at Bawdsey and the Converter Station at Bramford, passing the northern side of Ipswich. As a result of the strategic approach taken, the cables will be pulled through pre-installed ducts laid during the onshore works for East Anglia ONE Offshore Windfarm (EA ONE), thereby substantially reducing the impacts of connecting to the National Grid (NG) at the same location. The infrastructure to be installed for EA THREE, therefore, comprises:
 - The landfall site with one associated transition bay location with two transition bays containing the connection between the offshore and onshore cables;
 - Two onshore electrical cables (single core);
 - Up to 62 jointing bay locations each with up to two jointing bays;
 - One onshore Converter Station, adjacent to the EA ONE Substation;
 - Three cables to link the Converter Station to the National Grid Bramford Substation;
 - Up to three onshore fibre optic cables; and
 - Landscaping and tree planting around the onshore Converter Station location.
4. Since the granting of the DCO, the decision has been made that the electrical connection for EA THREE will comprise a high voltage direct current (HVDC) cable rather than a high voltage alternating current cable and, therefore, the type of substation that will be required is a HVDC converter station. The substation will, therefore, be referred to here as a 'converter station' and this amended terminology has been agreed with the relevant authorities on 15 October 2020. It has also been determined that only one converter station will be constructed rather than two and that the Converter Station will be installed in a single construction phase.

1.2. Purpose and Scope

5. This Landscape Management Scheme describes the landscape proposals and the general maintenance requirements for the landscape proposals for the Playford Corner Works Stage of the EA THREE construction works. This document has been produced to fulfil DCO Requirement 14 (1) & (2) which states:

Provision of landscaping

14.—(1) No stage of the connection works may commence until for that stage a written landscaping management scheme and associated work programme (which accords with the outline landscape and ecological management strategy) has been submitted to and approved by the relevant planning authority in consultation with Natural England.

(2) The landscaping management scheme must include details of all proposed hard and soft landscaping works, including—

(a) location, number, species, size and planting density of any proposed planting, including any trees;

- (b) cultivation, importing of materials and other operations to ensure plant establishment;
- (c) proposed finished ground levels;
- (d) hard surfacing materials;
- (e) vehicular and pedestrian access, parking and circulation areas;
- (f) minor structures, such as furniture, refuse or other storage units, signs and lighting;
- (g) proposed and existing functional services above and below, ground, including drainage, power and communications cables and pipelines, manholes and supports;
- (h) details of existing trees to be retained with measures for their protection during the construction period;
- (i) retained historic landscape features and proposals for restoration, where relevant;
- (j) implementation timetables for all landscaping works;
- (k) proposed finished heights, form and gradient of earthworks in relation to Work No. 64, Work No. 68 and/or Work No 69;
- (l) maintenance of the landscaping, including irrigation arrangements in relation to Work No. 64, Work No. 65, Work No. 68 and/or Work No. 69; and
- (m) soil retention, handling and protection.

6. The scope of this document relates to the Playford Corner Works Stage, as part of the onshore cable route that runs from the landfall location at Bawdsey to the Converter Station works located near Bramford, Suffolk. The works in this stage comprise Work No.s 39 and 40 (see Figure 1 Site Context Plan). Landscape Management Schemes have been produced for each stage of the onshore connection works and are provided under separate cover.
7. The Playford Corner Works will be some of the first works to be undertaken along the cable route. These works have been designated as a stage in their own right to allow the works to commence at this location prior to works commencing along the cable route as a whole (i.e. the main cable works construction phase). The Construction Consolidation Site (CCS) and the access to it will be constructed in Summer 2022 and remaining works (comprising the jointing bay installation, cable installation, access AP-W, haul road and reinstatement) will be undertaken as part of the main cable works construction phase.
8. This document has been prepared in accordance with the Outline Landscape and Ecology Management Strategy (November 2016, Document Reference – Deadline 6 / OLEMS V2/ Applicant).
9. The information contained herein shall be adhered to by the Principal Contractor and implementation and compliance will be monitored by the Construction Management Team. These measures will only be revised with the agreement of East Suffolk Council (ESC).

1.3. Background

10. The key elements and approaches in the landscape proposal for the Playford Corner Works are shown in the Playford Corner Works landscape mitigation plans (Appendix 2 – Drawings (EA3-LDC-CNS-DRG-IBR-000004 and EA3-LDC-CNS-DRG-IBR-000005) and include:
 - Proposed temporary protective fencing or suitable individual plant protection to protect trees and hedgerows during construction works.
 - Proposed replanting and reinstatement of hedgerows that have been felled to allow access or haul road construction;
 - Proposed reseeding of grassland areas as defined by the Project Ecologist.

2. ABBREVIATIONS

BS	British Standard
CCS	Construction Consolidation Site
CIRIA	Construction Industry Research and Information Association
CLO	Community Liaison Officer
DBEIS	Department of Business, Energy and Industrial Strategy

DC	Direct Current
DCO	Development Consent Order
EA ONE	East Anglia ONE Offshore Windfarm
EA THREE	East Anglia THREE Offshore Windfarm
EATL	East Anglia THREE Limited
EcoMP	Ecological Management Plan
ECoW	Ecological Clerk of Works
ES	Environmental Statement
ESC	East Suffolk Council
HVDC	High Voltage Direct Current
LPA	Local Planning Authorities
MW	Megawatt
NBS	National Building Specification
NG	National Grid
RPA	Root Protection Area
SCC	Suffolk County Council
SuDS	Sustainable Drainage System

3. CONSTRUCTION DETAILS

3.1. Cable Works – Overview

11. The construction works will be spread across a 37km corridor between the Suffolk coast at Bawdsey and the Converter Station at Bramford, passing the northern side of Ipswich. The cables will be pulled through pre-installed ducts laid during the onshore works for East Anglia ONE. The construction activity within each section along the onshore cable route will be as follows:
 - Any minor temporary modifications to the public road network;
 - Establish the Construction Consolidation Sites (CCSs);
 - Establish accesses to, and temporary haul road to, the jointing bay locations;
 - Establish temporary jointing bay compounds;
 - Excavate jointing bay pit to locate the existing ducts at each of the compounds;
 - Construct jointing bay;
 - Transport of cables to site, pull cables through ducts and undertake jointing;
 - Topsoil replacement and seeding;
 - Remove temporary compounds (jointing bays and CCS); and
 - Reinststate all disturbed land and permanent fences and hedges.

12. Some temporary modification of the existing road networks may be required such as localised widening, temporary widening or socketing of street signs and temporary moving of street furniture in order to allow larger vehicles than normal to access the jointing bays. This will be completed prior to the start of the main construction works within relevant sections of the cable corridor route.

13. EATL will require up to seven temporary construction compounds to aid in the construction of the proposed East Anglia THREE project. These have been designated as 'Primary Construction Consolidation Site' (PCCS) and 'Secondary Construction Consolidation Site' (SCCS) depending on their uses. Two PCCS and up to five SCCS will be installed, which will all be temporary and will be removed once construction is complete.

Table 3-1 – Construction Consolidation Site Locations

CCS Type	ID	Address
Secondary	A	Bullen Lane, Bramford, Ipswich, Suffolk IP8
Primary	B	Paper Mill Lane, Claydon, Ipswich, Suffolk IP6 0AP
Secondary	C	Witnesham Road, Ipswich, Suffolk IP6
Secondary	D	Playford Corner, Playford Mount, Ipswich, Suffolk IP6 9DS
Primary	E	Top Street, Martlesham, Suffolk IP12
Secondary	F	Clappits, Woodbridge Road, Newbourne, Woodbridge, Suffolk IP12 4PA
Secondary	G	Park Lane, Ipswich, Suffolk IP10

14. The PCCSs will:

- Form the main point of access onto the linear construction site;
- Provide areas for the storage of materials and equipment;
- House site administration and welfare facilities for the labour resources;
- Form an interchange hub for deliveries of material, equipment and resources; and
- Allow HGVs to park prior to entering the local road network during peak hours.

15. The SCCSs will act as hubs for the delivery of materials, equipment and resources along the route and will enable access to the cable route for construction. They will be of sufficient size to accommodate limited storage of materials, equipment and labour welfare facilities.

16. It is anticipated that 29 jointing bays will be required along the 37km cable route, in addition to a transition bay at the landfall. Each jointing bay will comprise a concrete box 10m long by 3m wide by 1.5m high buried so that the base is 2.5m below ground level. A jointing bay construction compound will be required adjacent to each jointing bay and will have hardstanding areas of up to 900m² within the compound which would typically measure 24m x 115m i.e. 2,760m². (in accordance with Requirement 12(11) which stipulates that the footprint must not exceed 3,740m²). The compounds will have hardstanding and accommodate containers, drum trailer movement, parking, and welfare. A typical layout is shown in Figure 2 of the Code of Construction Practice (EA3-LDC-CNS-REP-IBR-000047).

17. Existing accesses and farm tracks will be upgraded and used where possible to access the jointing bay locations. Once these accesses reach the cable corridor, the routes to connect to the jointing bays are referred to as ‘haul road’. The length of haul road for the cable route is limited by Requirement 12(12) of the DCO to 18.05km.

18. In addition, the ducts to be used for EA THREE, which were installed during the EA ONE project construction works, will require to be ‘proved’ to ensure that they are intact and free of debris. This will be undertaken by the use of foam pigs which will be driven under pressure from jointing bay to jointing bay. Each stretch of duct that was installed using Horizontal Direct Drilling (HDD) will, however, require duct-proving excavations at each end of the HDD, to allow the use of different size foam pigs, due to a difference in the diameter of these compared to the ducting installed using open trench techniques.

3.2. Playford Corner Works

19. Playford Corner Works comprise a stage of the onshore connection works and cover Work No.s 39 and 40. The infrastructure within these Work No.s comprises:

- The Playford Corner SCCS (CCS D) in Work No. 40;
- Jointing Bay 12 in Work No. 39;
- Two accesses with the public roads as follows:
 - Access AP-X (Work No. 40) southwards from Playford Mount, to access the Playford Corner SCCS and Jointing Bay 12; and
 - Access AP-W (Work No.39) eastwards from Holly Lane to access Jointing Bay 13 in Work No 38 (this Jointing Bay is not part of the Playford Corner Works);
- A crossing of Church Road (CR08 and CR09); and
- The access tracks/haul roads required to access Playford Corner SCCS, Jointing Bay 12 and also, in part, Jointing Bay 13 in Work No. 38.

20. These are shown on Figure 2.

3.2.1. Accesses AP-X and AP-W, the Crossing Point, Access Tracks and Haul Roads

21. Playford Corner SCCS will be accessed from Playford Mount using Access AP-X. This access was used for the EA ONE project but was fully reinstated following the EA ONE works, so will need to be constructed again under the EA THREE DCO. From Access AP-X, a new temporary vehicular access track of 360m length and 5.5m width will be used to access the Playford Corner SCCS and also reach the edge of the cable corridor (Work No. 39), where 190m of 5.5m wide haul road will link to Jointing Bay 12 (via a crossing of Church Road). The amount of temporary haul road required to access Jointing Bay 12 will be 190m.
22. Access AP-W will be constructed from Holly Lane, along with 670m of 5.5m wide haul road to reach Jointing Bay 13. This access was not used as part of the EA ONE construction works. 210m of this haul road will be within Work No. 38 and is not part of the Playford Corner Works.
23. A crossing of Church Road (CR08 and CR09) will be required. This will be in the same location as that used for EA ONE.
24. No watercourse crossings will be required for the Playford Corner Works.
25. The construction methodologies associated with the accesses, access track and haul roads are typically as follows:
 - Set out the access and track/haul road with the use of Global Positioning Systems (GPS) Real Time Kinematic (RTK) equipment;
 - Locate, divert and cap any existing field drains;
 - Set out and install drainage features the length of track to be constructed;
 - Remove vegetation, then remove and locally store topsoil material over the working width; seeding topsoil if it is to be stored for longer than 6 months;
 - Excavate to formation level and store any excess material;
 - Under-track drainage will be installed where necessary and in accordance with drainage requirements;
 - Place a geotextile onto existing subsoil to improve the bearing capacity of the sub-soil, depending on ground conditions, programme and landowner requirements; and
 - Place imported stone in accordance with the design to form the track structure.

3.2.2. Secondary Construction Consolidation Site (Work No. 40)

26. The Playford Corner SCCS will be a hub for the delivery of materials, equipment and resources. The dimensions of the Playford Corner SCCS will be 60m long by 20m wide covering a surface area of 1,200m², in accordance with Requirement 12(9)(a) of the DCO which limits the size of each SCCS to 1,200m². The Playford Corner SCCS will also be within the area previously used for the EA ONE SCCS in this location.
27. The construction of the SCCSs involves stripping of topsoil, importing and laying stone for the compound base and installing cabins and welfare facilities. Construction of the Playford Corner SCCS will take approximately 3 weeks and the methodology will be as follows:
 - The extent of SCCS will be marked out with the use of GPS RTK equipment;
 - Any existing field drains will be located, diverted and capped;
 - Drainage features will be set out and installed as required;
 - Security fencing will be erected around the perimeter of the SCCS;
 - Once vegetation has been removed, topsoil material over the SCCS area will be removed and locally stored and seeded if it is to be stored for longer than 6 months;
 - Any excess material will be excavated to formation level and stored; and
 - Imported stone will be placed in accordance with the design of the SCCS base structure.
28. The SCCS will be constructed first, with the jointing bay and cable pull through occurring at a later date (anticipated in 2024). It is intended that the SCCS will provide an early onsite presence for the onshore cable construction works and will be used as a base for mitigation and survey works being undertaken as well as for the construction team to visit site during the later stages of the planning and design process. It may also be used for stakeholder and other site meetings.
29. The Playford Corner SCCS will remain in situ for the duration of the onshore cable works, prior to being restored as described in Section 3.2.5.

3.2.3. Jointing Bay 12 (Work No. 39)

30. The jointing bay will be located within Work No. 39, 90m to the east of Church Road (Grid Ref 621869, 248384).
31. Once the location of the jointing bay compound has been established (using GPS RTK equipment), creation of the compound will commence with erection of temporary security fencing, removal of topsoil layer and installation of hardstanding areas.
32. The jointing bay will then be excavated to a depth of up to 2.5m with adequate slope batter or shoring on all sides of the excavation to prevent the soil from collapse. The existing ducts will be uncovered and concrete slabs constructed to provide a level working area. Two sump pits will be included to facilitate drainage and dewatering and water will be treated, where necessary, before being discharged. Installation and jointing of the cables will then take place, along with installation of earthing link boxes and fibre optic cable chambers, before area is back filled with subsoil.
33. The creation of the jointing bay compound and excavation of the jointing bay will each take a week.

3.2.4. Cable Installation

34. The electrical transmission cables will be delivered to the Playford Corner SCCS where they will be transferred to the jointing bay compound when needed. The cable drums will comprise abnormal loads and their delivery will be managed as set out in the Traffic Management Plan (EA3-LDC-CNS-REP-IBR-000039). Two cable lengths of approximately 1260m will be required to pull through between each pair of jointing bays. The cable ducts will be proved before the cable is pulled through. Once the cables are received at the jointing bay compound, they will be temporarily stored on the hardstanding area prior to installation in the pre-installed ducts.
35. Installation of the cables into the ducts between Jointing Bay 12 and Jointing Bay 13 (not part of the Playford Corner Works) will begin with a cable pulling system being installed into the bay. A steel bond and winching system with free spinning rollers will be installed along the bottom of the bay. Hydraulic jacks will raise the cable drum off the ground and a winch will be used to pull in cable using a pulling rope. A dynamometer will ensure the maximum pulling tension is not exceeded. Tension on the cable will be reduced using a biodegradable water-based lubricant. This process will be repeated for the second cable being installed in the duct. The cables will then be jointed once 2 cable sections (4 cables) have been installed.
36. It is expected that pulling and jointing operations would take approximately 2.5 weeks, typically spread over a three to four week period, with approximately five workers for each jointing bay. These works will then be repeated to install the cables between Jointing Bays 11 and 12.

3.2.5. Reinstatement

37. Following installation and jointing of the cables, the jointing bay, compound, accesses and haul roads will be reinstated with the stored topsoil and subsoil following trenching. If necessary, the subsoil will be 'ripped' prior to placement if compaction had occurred. Topsoil will be spread in such a way as to ensure that it does not become compacted. The topsoil will then be cultivated and reseeded (if required) and suitable hedgerow species replanted during the first appropriate planting season, in accordance with the Landscape Management Plan (EA3-LDC-CNS-REP-IBR-000042). Temporary fencing around any new planting would be removed once reinstatement was established.
38. The Playford Corner SCCS will remain in situ for the duration of the cable works and will then be removed and reinstated.

4. LANDSCAPE MANAGEMENT SCHEME GOVERNANCE

39. Prior to the commencement of construction at Playford Corner Works, a Landscape Management Officer will be appointed by the Principal Contractor to manage the implementation of this scheme. Contact details for the Landscape Management Officer will be submitted to stakeholders for their records prior to commencement of construction.

5. LOCAL COMMUNITY LIAISON

40. EATL is committed to providing clear communication to local residents. Proactive community liaison will be maintained, keeping local residents informed of the type and timing of works involved, particularly with regard to the type of activities which may occur in close proximity to receptors. As outlined in the Playford Corner Works Code of Construction Practice (EA3-LDC-CNS-REP-IBR-000047), a combination of communication mechanisms such as posters, notices, exhibitions, letters, newsletters, website updates and parish council meetings will be employed to keep local residents and businesses informed.

6. RELEVANT STANDARDS AND LEGISLATION

6.1. Applicable Standards and Good Practice

41. The soft landscape works will meet the following British Standards (BS) and guidance:

6.1.1. Tree and Hedgerow Protection During Construction

- BS 5837:2012 - Trees in relation to design, demolition and construction.

6.1.2. Tree Work by Arboriculturalists

- BS 3988:2010: Tree Work – Recommendations.

6.1.3. Topsoil Handling, Stripping and Storage

- BS ISO 15799:2019 Soil quality - guidance on eco-toxicological characterisation of soils and soil materials.
- BS 3882:2015 Specification for topsoil.
- BS 6031:2009 Code of practice for earthworks.
- BS 7562-4:1992 Planning, design and installation of irrigation schemes guide to water resources.
- BS 4428:1989 Guide of practice for general landscape operations (excluding hard surfaces) AMD 6784.
- BS 3882:2015 Specification for topsoil and AMD 9938.
- Construction Code of Practice for the Sustainable Use of Soils on Construction Sites, DEFRA

6.1.4. Quality of Trees and Shrubs

- BS 3936-1:1992 Nursery stock specification for trees and shrubs.
- BS 3936-5:1985 Nursery stock specification for poplars and willows.

6.1.5. Maintenance of Gardens/ Landscapes

- BS 7370-3:1991 Grounds maintenance recommendations for maintenance of amenity and functional turf (other than sports turf).
- BS 3998:2010 Tree work. Recommendations.

6.1.6. Horticulture

- BS EN 12579:2013 Soil improvers and growing media – sampling.
- BS EN 13037:2011 Soil improvers and growing media - determination of pH.
- PAS 100 2018 –Specification for composted materials.

6.1.7. Turf (if substituted for grass seeding)

- BS 3969+A1 2013 Recommendations for turf for general purposes
- BS 4428:1989 Code of practice for general landscape operations (excluding hard surfaces).

6.2. Relevant Legislation

- The soft landscape works will meet the following legislation:
 - The Hedgerows Regulations 1997.
 - Wildlife and Countryside Act 1981 (as amended).
 - The Construction (Design and Management) Regulations 2015.
 - Natural Environment and Rural Communities Act 2006.
 - Countryside and Rights of Way Act 2000.
 - Environmental Protection Act 1990.
 - Control of Pollution Act 1974.
 - The Waste (England and Wales) Regulations 2011.
 - Health and Safety at Work Act 1974

7. PROPOSED LANDSCAPE MITIGATION WORKS

7.1. General Overview

42. This document provides an overview of the design process undertaken for the Playford Corner Works (with respect to the landscape) and the corresponding proposed landscape mitigation works and their required maintenance to ensure successful plant establishment.
43. Felling of trees has been avoided and removal of hedgerows has been minimised as far as practicable during the design of the jointing bay location and the corresponding access and haul road.
44. The following surveys and desk information sources were used to inform the design of the necessary infrastructure for the cable route as a whole:
- Outline Landscape and Ecological Management Plan (OLEMS).
 - Schedule of Hedgerows taken from Part 2 of Schedule 9 of the DCO.
 - 2021 Arboricultural Impact Assessment (Appendix 1 of this document).
 - Ecological survey data for the cable route.
 - Ordnance Survey mapping and other aerial imagery.
45. The general strategy to minimise the loss of trees or hedgerows firstly required an understanding of the technical requirements and constraints involved with the location of the jointing bay and access. There was also the potential requirement to remove trees and hedgerows associated with the installation of the CCS however the locations of these have been selected to use the same sites as the CCS for the EA ONE project, they will also be smaller than required for EA ONE, in order to minimise removal.
46. The selection of the jointing bay locations (and thereby the accesses and haul roads) along the cable route as a whole was based on the following environmental criteria:
- A buffer of at least 55m from residential properties, where possible;
 - To be located close to field boundaries where possible
 - To be located close roads to facilitate access
 - To avoid known constraints, this includes
 - known archaeology;
 - hedgerows (>5m),
 - woodland and trees (>5m),
 - watercourses (>10m),
 - sensitive ecological receptors (such as important reptile habitat and grassland areas which contain notable plant species)
 - potentially contaminated sites, landfills, mineral extraction areas.
47. The accesses and haul roads to reach the jointing bay locations along the cable route have been designed to also avoid the above constraints. Where it has not been possible to route these to avoid hedgerows, then wherever possible these have been routed to use existing gaps or weak points in the hedgerows. Where existing gaps are not available in the hedgerow and the hedgerow has been previously crossed by EA ONE; then the crossing made by EA ONE will be the preferred crossing for EA THREE. This presumes the area crossed will consist of comparatively immature hedgerow (planted as part of EA ONE reinstatement programme) in relation to the rest of the hedgerow. Habitat removal would, where practicable, be restricted to the maximum haul road width of 5.5m.
48. The CCS location includes a 5m buffer around the site to minimise the impact upon sensitive hedgerows and trees, and a 10m buffer to minimise the impact upon watercourses. The need for removal of mature hedgerows and trees at the entrances to CCS is not anticipated. Trees will not be removed and hedgerows will be coppiced rather than removed. If these measures are insufficient, traffic management measures will be proposed to ensure safety of access e.g. use of banksmen, in consultation with ESC and SCC.
49. An Arboricultural Impact Assessment (Appendix 1) has been undertaken by Bowland Ecology and used to identify the arboricultural value of trees and hedgerows along the cable route, including the vicinity of Playford Corner Works. The assessment included is based on the arboricultural survey information for EA ONE which identified the Tree Category, health and estimated longevity of the tree, as well as the Root Protection Area (RPA) for each tree not previously surveyed.

50. The OLEMS identified a schedule of hedgerows which could potentially be affected by the onshore electrical transmission works for EA THREE. It identified 174 important hedgerows within the Development Order Limits, including four hedgerows along the boundaries of the Playford Corner Works (IDs 128-131) , as shown on Figure 23.4a -23.4g of the ES). The recommendations of the OLEMS hedgerow survey have been incorporated into the landscape mitigation works. The Arboricultural Impact Assessment (Appendix 1) provided a schedule of hedgerows impacted by the construction works, providing information on their species, height, and a note on their general condition and category. The EA ONE mitigation planting strategy provides detail of the replacement hedgerows.
51. Hedgerow schedules are presented in the Playford Corner Works landscape mitigation plans in Appendix 2, which draw on information from both the OLEMS Survey (2013 and 2014) and the 2021 arboricultural survey, including:
- 2021 arboricultural survey information: ID number, species notes and retention category;
 - OLEMS information: Reference number, notes on archaeological and botanical importance; and
 - Proposed landscape mitigation measures: proposed mitigation works to be applied to each hedgerow including protection during construction and replacement planting.
52. The hedgerows shown on the Playford Corner Works landscape mitigation plans (Appendix 2) EA3-LDC-CNS-DRG-IBR-000004 and EA3-LDC-CNS-DRG-IBR-000005 are identified by the 2021 Tree Survey ID.
53. Ordnance Survey mapping, aerial imagery, site photographs, technical and ecological constraints, hedgerow and tree survey data, RPAs and landscape notes were combined within a Geographic Information System (GIS) to provide a decision making tool to inform the siting of the works. The locations selected were designed to, wherever practicable, avoid physical effects on woodland, trees and hedgerows.
54. The results of the design exercise are included in the Playford Corner Works landscape mitigation plans (Appendix 2) which illustrate the proposed design and the landscape mitigation proposals.

Table 7-1 Summary of Landscape Plans

Drawing Name	Reference	Purpose
Playford Corner Works Landscape Mitigation Plans	Appendix 2 EA3-LDC-CNS-DRG-IBR-000004 and EA3-LDC-CNS-DRG-IBR-000005	A series of 2 sheets that illustrate the works at a scale of 1:1000. This series show: <ul style="list-style-type: none"> • the development consent order limits and proposed CCS, jointing bay, accesses and haul road; • the hedgerow schedule; • the tree surveyor’s tree schedule of trees within 15m of the works and their status; • hedge removal and tree / hedge protection; • landscape mitigation and replacement planting;
Planting Schedules– Hedgerows & Grasses (Appendix 3 EA3-LDC-CNS-BOM-IBR-000002	Planting schedule and typical landscape details for hedgerow and grasses planting.
Typical Details for Fencing	Appendix 4 EA3-LDC-CNS-DRG-IBR-000007	Typical landscape details for fencing.
Typical Details for Tree and Hedgerow Protective Fencing	Appendix 5 EA3-LDC-CNS-DRG-IBR-000008	Typical tree protection section and protective fencing detail, as per BS 5837:2012 to protect trees and hedgerows along the cable construction route.

7.2. Hedgerow Mitigation Planting

55. Landscape mitigation replacement planting works will be undertaken where the works result in physical loss of sections of hedgerows. The hedgerows to be removed have been previously crossed by EA ONE; and therefore the length of hedgerow to be removed and

replaced will consist of comparatively immature hedgerow (planted as part of EA ONE reinstatement programme) in relation to the rest of the hedgerow. The key elements of the replacement planting strategy are outlined as follows:

- Reinstatement of hedgerows will be undertaken using the planting mix specified in the Hedgerow Planting Schedule in Appendix 3.
- Grass re-seeding will be undertaken, to reinstate disturbed areas, using either a species rich mix or general purpose amenity mix for verges and embankments, depending upon the location.

56. Specific aspects of the replacement planting mitigation proposals are set out below.

57. The length of EA ONE hedgerow planting to be removed will be minimized as far as is practicable, and replacement hedgerow planting will be undertaken at the end of the construction stage in the first available planting season to reinstate the hedgerow, as shown in the Landscape Mitigation Plans in Appendix 2 and specified in the Hedgerow Planting Schedule in Appendix 3. The approach to this replacement hedgerow planting to be undertaken as part of the construction works is summarized as follows:

- Where a section of EA ONE hedgerow planting is to be removed, replacement planting will be undertaken along the original hedgerow field boundary line, using a bespoke hedgerow planting mix to replicate the EA ONE planting which in turn sought to enhance baseline conditions. The bespoke hedgerow replanting location is identified in the Landscape Mitigation Plan (Appendix 2) and the planting mix is specified in the Hedgerow Planting Schedule contained in Appendix 3. Planting will use shrubs of the same species and in the same general proportions as existed pre-construction (native, preferably of local origin). The replanting mix and pattern has been established on the basis of a survey in accordance with the Hedgerow Regulations, 1997.
- Bespoke hedgerow replanting is identified in the Landscape Mitigation Plans and Hedgerow Planting Schedule prefixed by HM, for example HM1, HM2 relating to the different species to be replanted at the various locations.
- All hedgerow plants will be bare-root feathered stock of 80-100 cm height, 1+2 transplants raised from seed.
- Hedgerows will be planted at 300mm centres (i.e. approximately 5 plants per linear metre) in a double staggered row, utilizing spiral guards with canes to protect young hedge plants.

58. The bespoke hedgerow replanting proposed at Playford Corner (HM18f) is listed in full in Appendix 3 and includes *Crataegus monogyna*, *Acer campestre* and *Prunus spinosa* species, to replicate the EA ONE planting which was chosen according to the existing hedgerow species present, the character of the hedgerow and soils. Table 7-2 summarises the species that are to be considered when selecting the bespoke planting mix as part of the bespoke planting proposals. The hedgerow replanting location and a full planting mix schedule are shown in Appendix 2 and 3.

Table 7-2 Hedgerow Planting Mitigation – Species to be considered for each Bespoke Planting Scheme

Hedgerow Planting Mitigation – Species for Bespoke Planting Scheme	
Botanical Name	Botanical Name
<i>Crataegus monogyna</i> x	Hawthorn
<i>Alnus glutinosa</i>	Alder
<i>Prunus avium</i>	Wild Cherry
<i>Prunus spinosa</i> x	Blackthorn
<i>Prunus cerasifera</i>	Cherry Plum
<i>Euonymus europaeus</i>	Common Spindle
<i>Malus sylvestris</i>	Crab Apple
<i>Rosa canina</i> x	Dog-rose
<i>Cornus sanguinea</i> x	Dogwood
<i>Sambucus nigra</i>	Elder
<i>Acer campestre</i> x	Field Maple
<i>Salix caprea</i>	Goat Willow
<i>Ilex aquifolium</i>	Holly
<i>Corylus avellana</i> x	Hazel
<i>Quercus robur</i>	Oak

7.3. Tree and Hedgerow Protection

59. Existing trees and hedgerows that are not to be removed (as set out in Appendix 3) will be retained and protected during the construction works.
60. Generally, all individual trees that are to be retained that are within the vicinity of the construction works will be protected by tree protection barriers, comprising 2m tall welded mesh panels (Heras) supported on the inner side by stabiliser struts, as per BS 5837:2012 - Trees in relation to design, demolition and construction, shown in Appendix 2 and detailed in the Arboricultural Impact Assessment (Appendix 1). Protective fencing to BS 5837:2012 is braced to protect trees and hedges from failure due to physical impacts. The fencing will be installed at a specified distance from the tree, defined by the edge of the RPA, as calculated by the Arboricultural Clerk of Works.
61. For hedgerows within the vicinity of the construction works, crowd barriers 1.1m high, will be installed along the routes shown in the landscape mitigation plans (Appendix 2) at a typical distance of 3m from the hedgerow.
62. An Arboricultural Clerk of Works will be appointed during construction to oversee the erection of protective fencing, the protection of trees and hedgerows to be retained and to ensure that all tree works are undertaken to the required standards. The appointment of the Arboricultural Clerk of Works will be made in advance of commencement and on appointment an introductory meeting will be convened with the Arboricultural Clerk of Works and relevant representatives from ESC. ESC will regularly be updated on timetable and progress of the works.
63. It is essential that the temporary tree and hedgerow protection fencing is erected correctly and in the position shown in the tree protection plans. The fencing will be in place and approved by the Arboricultural Clerk of Works before work commences at any location. Any conflicts with the position of the protective fencing, construction works and rights of way will be resolved on a case by case basis between the site managers and Arboricultural Clerk of Works.
64. Trees and hedges outside the construction area, but within the DCO Boundary, will not generally be protected as it is assumed they will be at a distance far enough not to incur unnecessary or accidental construction damage. Where deemed necessary by the Arboricultural Clerk of Works, for example if roots or branches came into the working area or at access points, tree protection will be installed.
65. The storage of materials, spoil, vehicles, welfare facilities etc. will not be permitted within the protective fencing (i.e. within the RPA and at least 3m from the tree).
66. Standard stock proof timber post and rail fencing and/or timber post and wire fencing will be used to complete boundaries, as required. Fencing will be installed prior to planting. Typical fencing details are illustrated in Appendix 5. A typical gate detail to provide maintenance and general access is also shown. The Playford Corner Works Fencing and Enclosures Plan (EA3-LDC-CNS-REP-IBR-000035) includes more details about the fencing strategy and coordinates the different types of fencing to be used for the works.

7.4. Grassland Re-establishment

67. The majority of land temporarily disturbed by the Works will return to agricultural cultivation following completion of the works. Areas of grassland present within the Playford Corner Works comprise the roadside verges and one section of semi-improved grassland (although this will not be impacted by the Works stage). In all temporarily disturbed grassland areas, topsoil would be stripped, stored and replaced to retain the seed bank. Areas of improved grassland will be reinstated as follows.
68. An improved grassland mix (G1) of native plants appropriate to the locality, will be used to reinstate areas of improved grassland impacted by the works (as identified in the Phase 1 Habitat Survey presented as Appendix 23.5 of the Environmental Statement (and confirmed during the 2020/2021 surveys), at the discretion of the landowner and with ecological input as required, with the species mix as specified in the schedule in Appendix 4 of this Landscape Management Plan. The species mix for improved grassland includes an abundance of rye-grass, cocksfoot, timothy and white clover, utilising a local provenance seed mix. Grassland will be established using a conventional seeding method such as broadcasting into a well-prepared seed bed. This mix will also be used for the re-seeding of field and private road margins, where not left to regenerate naturally.

69. The seed mix to be used for reinstating public road verges is to be Essential Road Verge Grass Seed Mix (E15) as specified by the Department of Transport. The seed mix to be used for reinstating private road verges is to be the improved grassland G1 mix.

7.5. Topsoil Storage Strategy

70. The key aspects of the topsoil storage strategy will follow the guidelines set out in the Construction Code of Practice for the Sustainable Use of Soils on Construction Sites (DEFRA 2009) and are outlined below.

7.5.1. General

71. Topsoil should be handled only in the right conditions of weather and soil moisture, using suitable machinery and in an appropriate way. Topsoil will not be stripped, transported or spread if the ground is waterlogged or frost bound or when the soil structure is likely to be damaged. Soil that is wet or very moist (wetter than the plastic limit) will be allowed to dry further before storage bunds are created, in accordance with the above referenced guidance document.
72. Before commencing work at a particular site, and following removal of vegetation, the topsoil from the area to be disturbed by construction activities or otherwise driven over by vehicles, will be stripped by earthmoving plant, appropriate to the size of the site, the volume of soil to be stripped and the haul distances to local storage. Movement of trucks or dumpers will be confined to designated temporary haul routes.

7.5.2. Stripping Topsoil and Vegetation Removal

73. In the planting season prior to the start of works, EATL will request that landowners avoid sowing new crops in any arable fields to be used. In other areas, any surface vegetation present will be removed by blading off, by scarification and raking, or where unavoidable, by application of a suitable non-residual herbicide applied not less than two weeks before soil stripping commences.
74. Topsoil will be stripped from all areas;
- (i) to be overlaid by hard surfaces or stored materials;
 - (ii) designated for subsoil storage;
 - (iii) requiring excavation into subsoil;
 - (iv) where major grading and/ or filling is to be carried out.
75. The topsoil will be removed to a thickness defined by depth below the surface and/or to a distinct colour change (subsoil level), to an average depth of 300mm.
76. Topsoil will not be stripped too deeply so that subsoil becomes incorporated, thereby reducing its quality fertility. Topsoil will not be removed from below the spread of trees and hedgerows which are to be retained.

7.5.3. Storage of Topsoil and Subsoil

77. Topsoil will be stored as per the Construction Code of Practice for the Sustainable Use of Soils on Construction Sites, published by DEFRA, as follows:
- Areas designated for subsoil storage will be stripped of topsoil first.
 - Topsoil and subsoil will not be allowed to be mixed or cross contaminated with one another or any other unsuitable materials. Materials will be stored like upon like i.e. topsoil will be stripped from beneath subsoil bunds, and subsoil from beneath overburden bunds. Bunds will be sealed.
 - To minimise compaction of topsoil and subsoil during stockpiling, the stockpiles will be formed by tipping or pushing into mounds.
 - Vegetation will not be incorporated into topsoil to be stored.
 - Topsoil will be stripped in the driest condition possible. Soils will not be stripped during or after heavy rainfall or when there are pools of water on the surface.
 - Topsoil will not be stripped too deeply so that subsoil becomes incorporated, thereby reducing fertility.
 - The topsoil heaps will not exceed 2m in height and 3m for subsoil.
 - When the entire storage area has been filled with heaps a tracked machine (excavator or dozer) will be used to level and firm the surface. To help shed rainwater and prevent ponding and infiltration, the tracked machine will compact and grade the sides to a smooth gradient.
 - The origin and quantity of topsoil stored in each bund will be recorded to aid reinstatement;

- Movement of trucks or dumpers will be confined to designated temporary access/haul routes.
- Stockpiles will be kept free of pernicious weeds.
- Duration of the subsoil and topsoil storage will be approximately 24 months for the jointing bay excavation and 3 years 8 months for the CCS and access to it. Long term storage will be seeded with low maintenance grasses as per grass mix G4 (Appendix 3). The seeding mix will be agreed with the landowner prior to seeding and may be subject to change at their discretion.
- A low maintenance grass mix (See Section 7.5.4) will be sown as soon as possible after creation of any soil storage mounds which are intended to remain in situ for more than 6 months or over the winter period. This will reduce soil erosion and to help reduce infestation by weeds that might spread seed onto adjacent land. The optimum months for sowing grass seed are April or September to October.
- Topsoil will not be removed from below the spread of trees and hedgerows to be retained.
- No soils will be stored within the RPA of trees or shrubs. All soil bunds will be placed 3m from any hedgerows to protect rootzones and to allow for maintenance access.
- No soils will be stored within 10m of a watercourse or within a flood plain
- Tracked equipment will be used wherever possible to reduce compaction.
- No driving on bunds unless strictly necessary, when tracked machinery is to be used.
- Where required managed drainage channels will be placed at the toe of stockpiles.

7.5.4. Grass for Long-Term Topsoil Storage

78. A low maintenance grass mix will be used to stabilise long-term topsoil storage mounds (G4), as specified in schedule in Appendix 4. Where agreed with the landowner, this may be a legume-rich mix to fix nitrogen into the soil to help support growth of other grasses.

7.6. Ecology

79. An Ecological Management Plan (EA3-LDC-CNS-REP-IBR-000003)(EcoMP) has been produced for the Playford Corner Works to fulfil Requirements 21 of the DCO and is provided under separate cover. Detailed information regarding ecological management does not form part of this Landscape Management Plan, however this section provides a brief summary of key ecological issues relating to the landscape management at the Paper Mill Lane Works.

7.6.1. Breeding Birds

80. Where possible, removal of vegetation will be timed to avoid the bird breeding season (March to August inclusive). Where scrub removal during the breeding season is unavoidable, a check by the Ecological Clerk of Works (ECoW) will be undertaken immediately prior to habitat removal to confirm that there are no occupied nests. Should any occupied nests be identified, an appropriate buffer zone (determined on the basis of the species concerned and the location of the nest in the context of the surrounding vegetation, but no less than 5m) would be implemented until the chicks have fledged. There are no Schedule 1 Birds known to be present within the vicinity of the Playford Corner Works.

7.6.2. Bats

81. No bat roosts have been found within the vicinity of the Playford Corner Works.

7.6.3. Reptiles

82. The Playford Corner site is predominantly arable (cereal) land which is of negligible value for reptiles. Areas of potential reptile habitat include; roadside verges along Church Road, and vegetation associated with a watercourse to the east. Both of these areas returned low population results for slow worm. Currently both locations are not considered to be at risk of impacts from commencement works in this location; as Church Road will not be used for access, and there will be no works within 250m of the watercourse to the east..

7.6.4. Other Protected or Notable Species

83. No other notable or protected species are present within the vicinity of the Playford Corner Works areas including Great Crested Newts, Badgers and Water Vole. Presence of badger is known to be close to the watercourse to the east however this is to be avoided by the works.

7.6.5. Notable and Invasive Species

84. No notable or invasive species have been identified in close proximity to the Playford Corner Works.

8. IMPLEMENTATION OF PLANTING

85. The landscape mitigation works that will be delivered are illustrated in the Playford Corner Works Landscape Mitigation Plans in Appendix 2, with planting details and mixes for hedgerows and grasses provided in Appendix 3. The following is an overview of the implementation of the proposed landscape mitigation works. All work will be undertaken according to BS 4428: 1989 Code of practice for general landscape operations. Contractors undertaking the planting will be briefed on the following requirements.

8.1. General

8.1.1. Seasonal and Climatic Conditions

86. The work will be carried out while weather and soil conditions are suitable for the relevant operations, avoiding periods of frost, strong winds or heavy rainfall. Planting will only take place during the following periods and in line with the below guidance:

- Late October to late March – planting of bare root feathered deciduous hedgerows.
- March to April or August to September for sowing of grasses.
- Any variation from these seasonal dates would be agreed with the ESC and SCC.
- Adequate watering and weed control will be provided to ensure successful establishment.
- Where bats are suspected to be present, advice will be provided from a licensed bat specialist and if appropriate, relevant licences obtained before any major tree works or hedge cutting is undertaken.
- Planting will take place in cultivated and moist friable soils, that that are not waterlogged.
- Planting will not take place into frost or snow covered soil.

8.1.2. Machines and Tools

87. Only machines and tools suitable for the site conditions and works will be used for carrying out the works. Hand tools will be used around trees, hedgerows and in confined spaces where it is impractical to use machinery.

8.1.3. Underground Service

88. The appointed landscape contractor will be responsible for the following:

- Familiarising themselves with the location of the underground services and taking all precautions to avoid any damage occurring to them.
- Immediately informing the appropriate body should any damage occur.
- Any claims arising from damage occurring to underground services.

8.2. Plant Material

8.2.1. Plant Quality

89. Plant material will be sourced from nurseries or contract grown to ensure suitability to local conditions and improve climate resilience. The project contract administrator will be notified before substitutions or should there be difficulty sourcing plant material with local provenance and any substitutions agreed with the local planning authority. Plant material will comply with the following:

- Plant quality will be in compliance with the relevant parts of BS3936 and BS5236 for any advanced nursery stock, where applicable.
- Plants will be materially undamaged, sturdy, healthy, vigorous and of good shape and without elongated shoots.
- Plants will have been grown in a suitable environment and hardened off.
- Plants will be free from pests, diseases, discoloration, weeds and physiological disorders.
- Plants will have a balanced root and branch system.
- Plants will be true to the plant names and sizes on the schedule.

8.2.2. Bare Root Plants

90. The majority of hedgerow plants will be planted as bare root feathered plants, as specified in the plant schedules in Appendix 3. All bare root plants will have vigorous and fibrous root systems which are reasonably equally developed in all directions and of adequate extents to support the growth of the plants root system and shall be kept moist and protected at all times up to the moment of planting. All plants will be protected by tree guards and supported with a single timber stake when planted. All tree guards will be biodegradable and/or removed when no longer required.

8.2.1. Seeds

91. All seed will be supplied to site in bags sealed by the supplier and clearly labelled with the percentage composition by weight mix of the seed mixture contained. Seed will not be dirty or damaged by vermin.

8.2.2. Native Hedgerow Species

92. All hedgerow species will comply with the following:

- Plant age will be a minimum of 2 years.
- Plants will have been transplanted at least once in the nursery (1+1).
- Bare root species will have a minimum of two substantial stems (breaks) from the lower third of the plant and a well branched form.
- Native hedgerow plants, 80-100cm high, planted at 300mm centres in a double staggered row, 300mm between rows.
- All plants to be protected by tree guards and supported with a single timber stake when planted.

8.2.3. Labelling

93. When supplied to the site all plants will be labelled in accordance with the relevant part of BS 3936 in order that they can be easily identified.

8.2.4. Substitutes

94. If specified plants are unobtainable or if it is known that they are likely to be unobtainable then suitable substitutions can be made following approval from the Project contract administrator and, in agreement with ESC and SCC.

8.3. Preparation for Planting

8.3.1. Site Clearance

95. Prior to cultivation all rubbish will be removed from the site, recycled where possible or taken offsite. All weeds, grass, residual crops and erroneous materials will be cleared from planting areas.

8.3.2. Soil Restoration

96. Topsoil and subsoil will be removed, stored and replaced in accordance with the Construction Code of Practice for the Sustainable Use of Soils on Construction Sites (Defra 2009). This guidance will be used as a reference and will be assessed against current legislation and controls. In order to ensure that the physical condition of the entire soil profile (topsoil and subsoil) will promote sufficient aeration, drainage and root growth, the following measures will be implemented as far as is practicable:

- Topsoil will be handled only when dry or slightly moist and using suitable machinery in an appropriate way;
- Tracked equipment will be used wherever possible to avoid compaction. Construction machinery will not be moved over topsoil or subsoil that has been replaced for planting.
- Multiple handling of soil materials will be minimised;
- Prior to spreading soil, the substrate shall be properly de-compacted to break up any panning to reduce flood risk and to promote deeper root growth. Decompaction shall be undertaken only when the soil is sufficiently dry to the full working depth. Toothed excavator buckets will not be used.
- The 'loose tipping' method, using dump trucks and hydraulic excavators to move and spread the topsoil will be utilised;
- Topsoil placement thickness will be appropriate to the anticipated rooting depth of the plants to be established and the quality of the underlying subsoil.
- After respreading topsoil, any large, compacted lumps should be broken down by appropriate cultivation to produce a fine tilth suitable for planting (<50mm maximum aggregate size), turfing and seeding (<10mm maximum aggregate size). The topsoil will be cultivated to its full depth using appropriate tillage equipment to de-compact and fully re-aerate. More than one cultivation may be required. Undesirable material (e.g. stones, fill materials and vegetation larger than 100mm in any dimension) brought to the surface during cultivation will be removed by picking or raking.
- If sustained heavy rainfall (e.g. >10mm in 24 hours) occurs during soil handling operations, work will be suspended and not restarted until the ground has had at least a full dry day or agreed moisture criteria (such as 'drier than the plastic limit') can be met. Lighter soil can generally be moved at a higher moisture content without damage than a heavy soil.

8.3.3. Cultivation

97. No digging will take place within the root spread of trees or hedgerows to be retained. Compacted topsoil will be broken up to its full depth.

8.3.4. Hedgerow Cultivation

98. Cultivation will comply with the following:

- Topsoil will be cultivated to the depth of 150mm at each location using suitable tools or machinery to ensure a firm friable tilth suitable for pit planting.
- Topsoil will be cultivated in two perpendicular directions to 'cross-rip' through any clay pans present.
- Topsoil surface will be left regular and even.
- All weeds, perennial weed roots, turfs of grass, roots and other material will be removed, including stones and clods of earth greater than 100mm in any direction, which have been brought to the surface.

8.3.5. Sowing Grasses

99. Sowing grasses will comply with the following:

- Weeds and grass will be cleared from site.
- Soil will be cultivated to a depth of 30mm using suitable tools or machinery, burying remaining vegetation.
- Soil will be harrowed and rolled to produce fine tilth and firm surface.
- The sowing area will be free from large ruts and stones or erroneous materials to allow for mowing later.

8.4. Planting and Seeding

8.4.1. Plant Handling, Storage and Transportation

100. The following will be undertaken during planting, handling, storage and transportation of plants:

- Comply with CPSE 'Handling and establishing landscape plants' (obtainable from the Horticultural Trades Association) Part I, Part II and Part III.
- Protect plants from frost and predation.
- Handle plants with care, protect from mechanical damage and do not subject to shock, e.g. dropping from a vehicle.
- Plants shall be kept moist and protected at all times up to the moment of planting.
- Careful and appropriate seed storage (e.g.. labelled appropriately, stored out of direct light, in dry conditions, checked for damage/spoiling).

8.4.2. Planting Hedgerow Transplants

101. The following will be undertaken during planting of hedgerows:

- All plants will be pit planted.
- Root dip will be used where considered necessary.
- Pits will be excavated to sufficient extents to allow roots of bare roots plants to be spread out without distortion to their shape and size.
- Excavated topsoil will be retained and appropriately stored for back-filling.
- Hedgerow plants will be spaced out evenly to create double staggered row following spacings specified on the plant schedule (Appendix 4).
- Plants will be placed in the centre of the planting pit with their main stem vertical and at such a depth that after planting firmed down soil is at the same level as the existing ground level.
- Back-fill will be carefully and thoroughly packed around plant roots or root ball and firmed in by heeling around the base of the stem.
- Individual protection will be installed around each plant unless otherwise protected by appropriate fencing.
- Where required, individual plants will be supported using canes or stakes as appropriate to ensure these are held upright during establishment.

- Mulches will be applied immediately after planting when the soil is moist and warm. Mulch material/matting will be applied on the surface of cultivated soil to a depth of 5cm – 10cm and a minimum of 500mm either side of the length of the hedge trench.

8.4.3. Sowing Grasses

102. The following will be undertaken during sowing of grasses:

- Sowing will take place into seed bed clear of all large stones, unwanted materials, weeds or vegetation.
- Seed mixture will be sown evenly onto prepared surface – either through hand broadcast, use of mechanical distribution (seed spreader).
- To get even distribution, seed mixture will be split in half and entire area sown twice at half rate. The first half will be sown in one direction and second in the other direction.
- Seed will be bulked out with a carrier such as sand or sawdust to get more even coverage.
- Seed will not be incorporated by drilling/harrowing – just broadcasted onto surface. Wildflower seeds are very fine and will not germinate if they are buried.
- Ground to be rolled once or twice after sowing to ensure good contact between seed and soil. This is particularly important in dry weather. The site will not be rolled if it is very wet.

8.4.4. Watering

103. Watering of newly planting hedges and seeded grasses will be undertaken as required to ensure the successful establishment and growth of hedgerows and germination and growth of seed mixes. The landscaping contractor will provide water bowsers to enable watering works.

9. MAINTENANCE OF PLANTING

9.1. Aims

104. The design aspirations for the landscape mitigation works at Playford Corner Works are:

- To replace physical hedgerow losses incurred during the construction works.
- To provide enhanced habitat opportunities in selected locations.

105. In order to achieve the above landscape objectives and ensure the success of the replacement hedgerows and seeding, an ongoing regime of landscape maintenance and management will be necessary. The overarching management and maintenance objectives are:

- To ensure full establishment of hedgerow planting to provide mitigation to the construction works, closure of gaps and eventual reinstatement of hedgerows.
- To ensure vegetation is kept healthy and vigorous, promoting good form, stem colour, flowering and structure of vegetation as appropriate.
- To ensure appropriate maintenance operations are undertaken as necessary to ensure public safety.
- To promote the creation of rich and ecologically diverse interconnected habitats where appropriate.
- To ensure pathways and access roads are kept free and clear of overhanging or nuisance vegetation.
- To allow the introduction of self-seeding of flowering species to encourage insects, which in turn may provide food sources for birds and bats to enhance local biodiversity.

106. ESC will be notified in writing of when the planting is complete and hence the five-year maintenance period will begin.

107. Maintenance will be undertaken for a period of five years for any hedgerow planted areas. Any shrub planted as part of the landscaping scheme that, within a period of five years after planting, is removed, dies or becomes in the opinion of ESC, seriously damaged or diseased, will be replaced in the first available planting season, with a specimen of the same species and size as that originally planted unless otherwise agreed in writing by the council. Replacement planting after this date may be requested at the discretion of ESC. Grassland maintenance during the establishment period will be undertaken for a period of 5 years within grassland habitat areas (G1, G4).

108. Planting aftercare will be delivered by contractors who can demonstrate appropriate experience and capacity to deliver effective and robust aftercare and provide a consistent quality of work across the whole project.

9.1.1. Legal Obligations

109. Maintenance will be carried out in accordance with relevant legislation. Maintenance staff will be aware of the legal obligations to protect nesting birds (mainly during the months of March to August) and bats which may roost against walls or trees during their active season (generally April to September inclusive, but can be active in March and October in warmer weather). A suitably qualified ecologist will check for protected species prior to the start of relevant maintenance activities.

9.1.2. General Requirements

110. The following requirements for maintenance will apply to all planted areas within cable construction works as shown in the Landscape Mitigation Plans and Schedule (Appendix 2):

- All landscape maintenance tasks to be undertaken by a competent contractor on behalf of EATL or the Offshore Transmission Owner (OFTO)¹ following divestment of the works.
- All areas to be regularly monitored and assessed for establishment and condition, in order to inform the maintenance tasks required.
- All trimming and pruning of plants to be carried out once plants have flowered, seeded and shown fruit. Any management works related to soft landscape generally to be left until late Autumn, preferentially September.
- Access to site and maintenance hours to be agreed with landowner.
- All areas to be kept tidy in appearance with weeds removed as required, while allowing for naturalisation to enable development of diverse ground flora.
- No fertiliser or pesticides will be used.
- All arisings from landscape maintenance, where not used as a mulch, to be used in the creation and maintenance of habitat piles or hibernaculum, in accordance with a waste exemption.
- Watering to be carried out as required to ensure the successful establishment of the soft landscape proposals as detailed in Tables 9-1 to 9-5.
- All planted areas within the EA THREE DCO boundary shown in the soft landscape general arrangement drawing (Appendix 2) will be kept clear of weed growth for the first 3 growing seasons; after 3 years, a herb layer can be allowed to return.
- Weed control generally throughout all areas of the site to include spot herbicide treatment or manual removal of the following:
 - all broad leaved weeds.
 - docks (*Rumex spp.*).
 - injurious weed species listed in the Weeds Act 1959 and Wildlife and Countryside Act 1981.
 - nettles (*Urtica spp.*).
 - ragworts (*Senecio spp.*).
 - thistles (*Cirsium spp.*).
 - willowherb (*Epilobium spp.*).
- Controls will be implemented in accordance with the EcoMP (EA3-LDC-CNS-REP-IBR-000003) in any areas of invasive or notable species.
- There will be an agreed procedure for joint annual inspection of all planting areas by representatives of ESC and EATL at the end of each growing season and for each year of the five-year aftercare period. Areas found not to be thriving will be treated to such additional works as are required to rectify the situation within the next growing season.
- Any replacements for those plants that have not established successfully in the first five years of planting to be replaced the first available planting season with species, size, shape and form to match those of the existing planting scheme, unless otherwise agreed in writing by ESC.
- Suspension of the aftercare period for any part of the scheme may occur in the event that in the opinion of ESC there was a significant failure of the planting scheme that could not be satisfactorily remedied in the following planting season, and or part of the planting scheme was failing to progress to the extent that it would not achieve the objectives of the scheme within the specified aftercare period.

¹ Although the EA THREE onshore transmission works will be constructed by EATL, in the UK, separate Offshore Transmission Owners (OFTOs) take responsibility for offshore transmission assets, such as the EA THREE cable route under long-term OFTO licences. The landscaping associated with the cable route will, therefore, be maintained following divestment, by an OFTO

111. The following section outlines the aims of the landscape management strategy in relation to the soft landscape proposals and includes a description of maintenance tasks that will be undertaken.

9.2. Proposed Hedgerow Planting (HM)

112. The proposed replacement hedgerow planting (HM) includes a bespoke planting mix appropriate to each location, generally consisting of mix of native species, typical to the area and is intended to provide compensatory hedgerow planting to replace sections of hedgerow removed as part of the cable construction works. Planting will be undertaken along the original hedgerow line where space, conditions and constraints allow, as indicated in the landscape mitigation plans (Appendix 2). The replacement hedgerow planting (HM) has a number of aims:

- It will quickly establish and reinstate the hedgerows removed as part of the works providing a uniform size and height.
- It contributes towards maintaining the landscape character in the region, where hedgerows are a distinctive element of the landscape.
- It contributes to enhancing the natural environment by providing “green corridors” and additional habitat.

113. Details of the maintenance of the hedgerow planting are detailed in Table 9-1:

Table 9-1 Maintenance of Hedgerows

Hedgerow Maintenance	
Pruning, Trimming and Thinning	
1	If the transplants are well branched, cutting back will not be necessary. Otherwise, for the first three years after planting, maintenance will concentrate on shortening the longer shoots and just tipping back shorter ones to encourage branching and dense growth without much loss in height. This trim will take place during late Autumn, preferentially September, ensuring ecological checks are undertaken as required.
2	From the third year onwards, trim the sides of the hedge, aiming for a well trimmed full A-shape (in cross section) to ensure that sunlight reaches the top and bottom equally. Aim for a width of about 1m at the base, tapering upwards to the desired height (approx. 1.1.m). Ideally, not all of the hedge should be pruned in the same year, treat either in alternate sections or alternate sides of the hedge. All arisings will be left in situ to decay back into the soil and feed the establishing hedge, subject to a waste exemption.
3	After 3 years’ establishment of new hedge planting, maintain hedges in accordance with the following: <ul style="list-style-type: none"> • Where existing hedge is higher than 3.6m allow for hedge work including coppicing appropriate species, removing old growth to allow regrowth of shoots from the base. • Remove excess leaf mould, deadwood and other material from base of hedges to keep soils moist and encourage growth. • Replant gaps with species indicated in schedule (Appendix 4).
Weed Control	
1	Hedgerows will be kept clear of weed growth for the first 3 growing seasons; after 3 years, a herb layer can be allowed to return
2	Mulching will be undertaken as the primary form of weed control. Mulching helps to moderate soil temperatures, reduce soil compaction and moisture loss (especially on lighter soils), provide nutrients, improve soil structure, while keeping mowers and trimmers away from the trunk. These benefits result in more root growth and healthier plants.

3	The use of wood chips taken from chipped material from the arisings of removed hedgerow sections and felled trees is acceptable and encouraged (subject to a waste exemption). A stockpile of chipped material will be kept near to each hedgerow crossing for use as mulching material.
4	Mulches will be applied immediately after planting, when the soil is moist and warm. Mulch material/matting will be applied on the surface of cultivated soil, when the soil is not frozen, to a depth of 5cm – 10cm. Mulch will be applied to a minimum of 500mm either side of the length of the hedge trench, guided by whether weed growths are outgrowing and smothering the hedge at this width. Mulch will be freshened or replaced every 2-3 years or as required, to maintain a minimum 5cm mulch depth. Mulch will be kept at least 8-15cm away from the trunk of young hedgerow trees.
5	Keep areas weed-free by a combination of herbicide applications and hand-weeding (preferably) or hoeing. Ensure that the methods used will cause a minimum of damage to adjacent planted areas. Do not allow nylon filament rotary cutters or other mechanical tools closer than 200mm to the stem of any hedge plant, carry out operations close to stems using hand tools. Maintain a minimum of 500 mm either side of the hedge as a grass & weed-free area
6	Herbicide application: A foliar acting translocated or contact herbicide will be applied to emergent weeds, ensuring adjacent flora is not in contact with herbicide. Herbicide should only be used where hand weeding is not possible/feasible
7	Hand weeding: Hoe and loosen the soil throughout the planting areas, taking care to avoid disturbance of roots of planted material. Remove weeds entirely, including roots. Remove the minimum of soil and minimise disturbance to plants, bulbs and mulched surfaces. On completion, rake areas to a neat condition.
Watering	
Watering is required at planting, apply a heavy watering to the full rooting depth. If the addition of bark mulch is delayed, then apply mulch only after rain or watering. Take into account published meteorological data on rainfall for any given period, in particular in periods of Spring drought during April, May and June. Therefore, if required, undertake a heavy watering to full rooting depth. The contractor will need to arrange for a mobile water bowser or tanker to bring the required clean water to site.	
Re-firming	
Hedge plants will be maintained in a firm position in the ground and all stakes and guards will be checked regularly. Particular timing of inspections: after strong winds, frost heave and other disturbances. Replace missing rabbit guards and report any significant failures. All guards will be biodegradable and/or removed when no longer required. Spiral guards and stakes to be removed after 5 years.	
Failures	
Towards end of first growing season a survey will be undertaken to assess successful uptake of planting and make recommendations for replacements. Any hedgerow trees planted that, within a period of 5 years after planting, is removed, dies or becomes, in the opinion of the relevant planning authority, seriously damaged or diseased must be replaced in the first available planting season with a specimen of the same species and size as that originally planted. A report on the establishment of the hedgerows is to be shared with ESC stating what was found and any remedial action that is to be taken.	

9.3. Improved Grassland (G1)

141. Any improved grassland areas that are impacted by the works will be reinstated to the same or better condition (as identified in the Phase 1 Habitat Survey(Appendix 23.5 of the Environmental Statement and confirmed by the 2020/2021 surveys), at the discretion of the landowner with ecological input, with an improved grassland species mix of local provenance. Grassland will be established using a conventional seeding method such as broadcasting into a well-prepared seed bed, with the aim is to create a healthy and full improved grassland sward to reinstate ground disturbed by the works.

142. Monitoring of planting and seedlings will be undertaken 5 years after the completion of the works. Walkover surveys, following the baseline methodology will be undertaken in years 1, 3 and 5.

Table 9-2 Maintenance of Improved Grass

Improved Grass Maintenance
<p>Cutting / grazing</p>
<p>Improved grassland areas will be relatively low maintenance, with appropriate low frequency cutting or grazing at the landowner’s discretion, with the aim of reinstating disturbed ground to grassland reflecting the local characteristic improved grassland over several years. Grazing would be the preferred option once grassland is established, excluding livestock from early March to July and grazing later in the year between August and December, allowing tussocks and taller grasses to remain, without over-grazing. Mowing will be undertaken if grazing is not available, cutting once a year, to an approximate length of 150mm, in September (allowing more plants to have chance to set seed) and removing cuttings from site. If there are problems with aggressive vegetation (as confirmed by maintenance inspections), cutting earlier in the year would be beneficial (e.g. July-August).</p>
<p>Weed Control</p>
<p>Grass cutting will generally suppress broadleaf weeds, however weed control will be undertaken as necessary, particularly during the early years of establishment, to include spot herbicide treatment or manual removal of weeds such as thistle and ragwort.</p>
<p>Watering</p>
<p>Watering will be undertaken as required during dry spells for establishment only; the intention is to create a sustainable grass sward not reliant on irrigation systems. If watering is required, due to unseasonably dry weather during the establishment period, then the contractor will need to arrange for a mobile water bowser or tanker to bring the required clean water to the required location</p>
<p>Plant Failures</p>
<p>Maintenance visits to confirm establishment of grasslands to take place within the first 5 years after the completion of the works, with additional seeding undertaken as required. A full maintenance check and report to be provided at the end of the first year (or following year depending on timing of seeding). A report on the establishment of the grasslands is to be shared with ESC stating what was found and any remedial action that is to be taken.</p>

9.4. Topsoil Storage Mix (G4)

149. A topsoil storage low maintenance grass mix (G4) will be used immediately following topsoil stripping to stabilise long term top soil storage. Where agreed with the landowner, this may be a legume-rich mix to fix nitrogen into the soil to help support growth of other grasses. The G4 sward can also be ploughed back in to improve soil structure (subject to a waste exemption, if required).

Table 9-3 Maintenance of Topsoil Storage

Topsoil Storage Maintenance
<p>Cutting</p>
<p>The emergent grass sward will be mown or strimmed initially to a cutting height of 50mm to promote tillering of the grasses. This will in turn both stabilise the soil surface and restrict opportunities for weed species to invade the sward. The sward will subsequently be mown to a height of 50mm once in April/May and again in August/September during the construction period, to allow for flowering and seeding (if of appropriate mix) to provide a resource for invertebrates and birds, unless growth rates or climatic conditions indicate otherwise.</p>

Weed Control
At all times during the site working and restoration programme good agricultural practice will be used to contain weed growth and the appropriate herbicide will, if required, be applied in accordance with manufacturers’ recommendations. Herbicide is however, to be avoided where possible. Ideally there is to be no herbicide use on bunds throughout the entirety of the storage period. It is only to be used just before reinstatement to kill off vegetation. Weed control will be undertaken as necessary to include manual removal, or if required spot herbicide treatment. Any use of herbicide to be recorded. Any areas of failed grass will be cultivated and reseeded in the next seeding season.
Watering
Unlikely to be required as the intention is to create a temporary grass sward not dependent upon external manual watering or irrigation. However, should additional watering be required due to extremely unseasonal dry conditions or to ensure the bund structure is retained, then the contractor will need to arrange for a mobile water bowser or tanker to bring the required clean water to site.

9.5. Programming of Maintenance Tasks

- 156. The following is an indicative annual schedule of maintenance visits that will be undertaken for the first 5 years of establishment. This provides a reasonable frequency of the more common operations, and a good indication of the required level of intensity of management required but is not intended to be fully comprehensive or restrictive.
- 157. An appointed contractor will be required to construct a schedule of operations specifying operations and frequency using his own experience and horticultural knowledge and understanding of the growing conditions prevalent within the local area.
- 158. The ongoing programme of maintenance work will include proposed frequency of visits and operations detailed in the specification, i.e. pruning. It will also include scheduled dates for:
 - Infrequent operations such as re-spacing of plants, pruning, topping up of mulch, replacement of plants / restocking of beds etc.;
 - Planting review and refurbishment;
 - Monitoring and review; the effectiveness of the management operations is to be closely and continually monitored and reviewed annually, with any resulting changes incorporated into the subsequent years’ programme.

Table 9-4 Hedgerows (HM) – activities and number of visits

Month	Watering	Weeding	Re-firming
January			
February			
March			1
April	2		
May	2	1	
June	2		
July	2	1	
August			
September		1	
October			1
November			
December			

Note: Watering as necessary during periods of drought in the establishment period.
Spiral guards and stakes to be removed as required.

Table 9-5 Improved Grassland areas (G1) – activities and number of visits

Month	Weeding	Mowing (neat margins along verges)	Mowing (areas of longer grass)
January			
February			
March			
April			
May	1		1
June			
July	1		
August		√	
September	1	√	1
October		√	
November		√	
December		√	
Note: Additional visits may be required to increase the frequency of mowing during the summer months to keep weed growth under control.			

10. REFERENCES

DEFRA, 2009, Construction Code of Practice for the Sustainable Use of Soils on Construction Sites, DEFRA, London https://assets.publishing.service.gov.uk/government/uploads/system/uploads/attachment_data/file/716510/pb13298-code-of-practice-090910.pdf

Forestry Commission, 2017, The UK Forestry Standard, The governments’ approach to sustainable forestry, Forestry Commission, Edinburgh

APPENDIX 1 ARBORICULTURAL IMPACT ASSESSMENT

FOR DISCHARGE

ARBORICULTURAL METHOD STATEMENT

Project:	East Anglia THREE Offshore Windfarm
Site:	Butts Road & Holly Lane, Ipswich, IP13 6PH
Doc. ID.:	EA3-OND-CNS-REP-IBR-000002 – PCCS Playford
DCO Requirement:	14(1) & (2)

Prepared by:	Joseph Lambert <small>BSc(Hons) MArborA</small>
Report Date:	20 December 2021
Job Ref:	BTC2293
Client:	Scottish Power Renewables

Page:	1 of 4
--------------	--------

Scope of Arboricultural Method Statement

- This Arboricultural Method Statement (AMS) relates specifically to the planned construction works at the above site.
- The AMS should be read in conjunction with the appended Temporary Protective Fencing Specification and Tree Protection Plan (TPP) (reference BTC2293 – TPP(P))
- The purpose of the AMS is to consider the potential effects of the construction operations on the retained trees, and sets out how any identified adverse impacts are, as far as is practicable, to be avoided.
- From commencement of construction, and throughout the site works until completion, the methodology shall be implemented in the sequence and manner detailed in the Sequence of Works.
- It shall be the contractor's responsibility to ensure that the works are carried out in strict accordance with the obligations and responsibilities of the AMS and, in turn, they will be accountable for any breaches of the obligations and responsibilities.

Site Inspections & Reporting by Project Arboriculturist

- Prior to the commencement of the site works, all personnel who might be charged with overseeing development related works shall be provided with the contact details of the Project Arboriculturist.
- In turn, it is the responsibility of the Site Manager to report any tree related issues, including deviations from the AMS, directly to the Project Arboriculturist, who will then visit the site and make recommendations to the Site Manager on how best to rectify the situation.
- The Project Arboriculturist shall be engaged to carry out site inspections for the duration of the works at suitable intervals (NB: no more than 31 days shall elapse between site inspections, excepting during periods of site inactivity), in order to ensure compliance with the AMS and any consent conditions pertaining to tree issues. NB: It may be appropriate for the Project Arboriculturist to undertake remote site inspections with the Site Manager via video link where the risk of tree damage is considered negligible.
- Subsequent to each site inspection the Project Arboriculturist shall complete a monitoring report detailing any problems encountered and breaches of the agreed working methods or tree related consent conditions, and any measures required to rectify such problems, and the report shall be forwarded to the Site Manager and the Client's Representative by email.
- The Project Arboriculturist shall report any tree related issues and/or breaches of the AMS that they consider to be significant in relation to retained tree health and/or structural stability directly to the Client's Representative, who shall then report directly to the Council Tree Officer.
- In the event that the Project Arboriculturist's contract is terminated, then the Client's Representative shall issue a written notice to all relevant parties to this effect, inclusive of the Council Tree Officer, within 5 business days following termination.

Council Tree Officer

- In the event that the Council Tree Officer should visit the site and identify any tree related issues, they will then report any problems directly to the Site Manager who, in turn, will report to the Project Arboriculturist via the Client's Representative. NB: In the event of a site visit the Council Tree Officer must comply with the site visitor rules in place.
- The Project Arboriculturist will then visit the site with the Client's Representative and make recommendations to the Site Manager on how best to rectify the situation.

Site Personnel

- All personnel engaged in the execution of the construction works shall be provided with a copy of the AMS and the TPP.
- In turn, all such personnel shall be instructed in the protection of trees, as set out in this AMS.

Sequence of Works & Revisions

- The site works shall be carried out in strict accordance with the 'Sequence of Works' detailed in the table overleaf.
- Any proposed deviations from the 'Sequence of Works' shall be reported to the Project Arboriculturist (via the Client's Representative), who will then review and comment on the proposed modifications accordingly.
- Where the amendments are considered acceptable in relation to retained trees, then the Project Arboriculturist shall prepare and issue a revised version of the AMS to the Client's Representative for comment.
- Should the Client's Representative consider the revised AMS to be acceptable, then the Project Arboriculturist shall issue the report to the pertinent persons, specifically the Site Manager and the Council Tree Officer.

ARBORICULTURAL METHOD STATEMENT

Project:	East Anglia THREE Offshore Windfarm
Site:	Butts Road & Holly Lane, Ipswich, IP13 6PH
Doc. ID.:	EA3-OND-CNS-REP-IBR-000002 – PCCS Playford
DCO Requirement:	14(1) & (2)

Prepared by:	Joseph Lambert <small>BSc(Hons) MA ArborA</small>
Report Date:	20 December 2021
Job Ref:	BTC2293
Client:	Scottish Power Renewables

Table of Sequence of Works:

No.	Operation*	Timing	Responsible Professional	Arboricultural Supervision	Specific Tree Protection Measures During Operation#
i	Pre-contract site meeting between: <ul style="list-style-type: none"> ▪ Site Manager; ▪ Project Ecologist; ▪ Project Arboriculturist; and ▪ Client's Representative 	To be completed prior to any other works, including deliveries of material, plant, etc.	Site Manager overseen by Client's Representative	N/A	None - however, specific methods of tree protection shall be discussed in detail, in particular the temporary protective fencing types and locations (see Operation iv) and, if identified as necessary, a schedule of supplementary recommendations shall be agreed between parties and subsequently prepared and distributed to said parties by the Site Manager
ii	Carry out approved tree and hedge works (i.e. pruning and removals) in accordance with the DCO NB: Removals understood to be limited to new replacement planted hedgerow following EA1 works.	Only to commence on completion of Item i	Tree Contractor overseen by Site Manager	Project Arboriculturist to verbally advise Tree Contractor with regard to tree works where considered necessary by Site Manager	<p>No vehicular or plant access within retained trees' Root Protection Areas (RPAs) under soft surfaces</p> <p>Any tree stumps where close to or within retained trees' RPAs should be cut to just above ground level and left in situ where proposed site usage allows</p> <p>Where stump removal is required within RPAs this should only be carried out using a stump grinder, and not a mechanical excavator, positioned on a temporary ground guard for duration of works in order to minimise ground disturbance</p> <p>Holes should be backfilled with a suitable material following stump removals</p>
iii	Mark up, on site locations and extents of Temporary Protective Fencing for retained trees as detailed on the TPP.	Only to commence on completion of Item ii	Fencing Contractor overseen by Site Manager	Project Arboriculturist to verbally advise Fencing Contractor with regard to siting and construction of fencing where considered necessary by Site Manager	<p>No vehicular or plant access within retained trees' RPAs under soft surfaces</p> <p>No storage of site materials within RPAs</p>

*Note 1: All operations to be subject to risk assessments and method statements to be provided by applicable contractor(s)

#Note 2: The General Recommendations in Respect of Works, detailed at page 4, shall also be adhered to by all site operatives during all work operations

°Note 3: Refer to appended Temporary Protective Fencing Specification

continued overleaf

ARBORICULTURAL METHOD STATEMENT

Project:	East Anglia THREE Offshore Windfarm
Site:	Butts Road & Holly Lane, Ipswich, IP13 6PH
Doc. ID.:	EA3-OND-CNS-REP-IBR-000002 – PCCS Playford
DCO Requirement:	14(1) & (2)

Prepared by:	Joseph Lambert <small>BSc(Hons) MArborA</small>
Report Date:	20 December 2021
Job Ref:	BTC2293
Client:	Scottish Power Renewables

Table of Sequence of Works (cont.):

No.	Operation*	Timing	Responsible Professional	Arboricultural Supervision	Specific Tree Protection Measures During Operation#
iv	Erect Temporary Protective Fencing to protect RPAs of specific retained trees and hedges, in locations identified on the TPP.	To be erected immediately on completion of Item iii	Fencing Contractor overseen by Site Manager on advice of Project Arboriculturist	Project Arboriculturist to visit site, appraise protection measures, and provide brief report to Council Tree Officer via Client's Representative following erection works NB: it shall be the Site Manager's responsibility to arrange the Project Arboriculturist's site visit	No vehicular or plant access within retained trees' RPAs under soft surfaces The temporary protective fencing to protect trees and groups shall be installed in strict accordance with the Temporary Protective Fencing Specification, with 'Type 2' fencing (see Specification) to be utilised in preference and 'Type 3' fencing used where ground conditions dictate (NB: Any proposed deviations from the Specification should be discussed with the Tree Officer, and, where necessary, agreed in writing. It is understood standard 'crowd barriers' were used effectively to protect hedges during EA1 and their use for hedgerow protection as part of EA3 should be agreed with LPA tree officer) No storage of site materials within RPAs
v	Commence main construction phase	Only to commence on completion of Item iv	Site Manager	Project Arboriculturist to carry out monthly site visits and provide subsequent monitoring reports to Client's Representative	All site operations involving plant with booms, jibs and counterweights to be planned in advance to prevent contact with retained trees, and works adjacent to trees to be conducted under supervision of a banksman under arboricultural direction, in order to ensure that adequate clearances from retained trees are maintained
vi	Complete main construction phase and remove all associated operational materials except the Temporary Protective Fencing	Only to commence on completion of Item v	Site Manager	Project Arboriculturist to visit site following completion of construction works and prior to Operation viii, below. NB: it shall be the Site Manager's responsibility to arrange the Project Arboriculturist's site visit	All site operations involving plant with booms, jibs and counterweights to be planned in advance to prevent contact with retained trees, and works adjacent to trees to be conducted under supervision of a banksman under arboricultural direction, in order to ensure that adequate clearances from retained trees are maintained
vii	Remove Temporary Protective Fencing	Only to commence on completion of Item vi	Fencing Contractor overseen by Site Manager	Project Arboriculturist to verbally brief Fencing Contractor prior to removal of Temporary Protective Fencing	No vehicular or plant access within retained tree's RPA under soft surfaces

*Note 1: All operations to be subject to risk assessments and method statements to be provided by applicable contractor(s)

#Note 2: The General Recommendations in Respect of Works, detailed at page 4, shall also be adhered to by all site operatives during all work operations

°Note 3: Refer to appended Temporary Protective Fencing Specification

ARBORICULTURAL METHOD STATEMENT

Project:	East Anglia THREE Offshore Windfarm
Site:	Butts Road & Holly Lane, Ipswich, IP13 6PH
Doc. ID.:	EA3-OND-CNS-REP-IBR-000002 – PCCS Playford
DCO Requirement:	14(1) & (2)

Prepared by:	Joseph Lambert <small>BSc(Hons) MArborA</small>
Report Date:	20 December 2021
Job Ref:	BTC2293
Client:	Scottish Power Renewables

Page:	4 of 4
--------------	--------

Table of Sequence of Works (cont.):

No.	Operation*	Timing	Responsible Professional	Arboricultural Supervision	Specific Tree Protection Measures During Operation#
viii	Commence replacement tree and/or hedge planting within and in close proximity to retained trees' RPAs	Only to commence on completion of Item vii	Landscaping Contractor overseen by Site Manager in consultation with Project Arboriculturist	If requested by the Council Tree Officer, then Tree Officer and Project Arboriculturist to visit site following completion of works. NB: it shall be the Site Manager's responsibility to arrange the Council Tree Officer's and Project Arboriculturist's site visit	Landscaping Contractor to provide Project Arboriculturist, via Site Manager, with a detailed schedule in regards to the maintenance of any newly planted trees in accordance with s8 of BS5837:2012 All planting works to be undertaken in accordance with s7 of BS5837:2012, including no significant level changes within retained trees' RPAs No vehicular or plant access within retained trees' RPAs under soft surfaces

*Note 1: All operations to be subject to risk assessments and method statements to be provided by applicable contractor(s)

#Note 2: The General Recommendations in Respect of Works, detailed at page 4, shall also be adhered to by all site operatives during all work operations

°Note 3: Refer to appended Temporary Protective Fencing Specification

General Recommendations in Respect of Works:

- All tree works should be implemented by suitably qualified and experienced arboricultural contractors prior to the erection of the Temporary Protective Fencing.
- All tree works should conform to British Standard BS3998:2010 Tree Work - Recommendations.
- Performance of all arboricultural operations and use of equipment should be in accordance with current directives of the Health and Safety Executive (HSE) and industry codes of practice.
- All operatives should be equipped with and use Personal Protective Equipment (PPE) in accordance with current directives of the HSE and industry codes of practice.
- All tree stumps scheduled for removal that are located within a distance of 6.0 metres of any retained tree should be removed by mechanical stump grinder and not by mechanical excavator.
- All possible efforts should be made by the tree contractor and any other site operatives to prevent damage to retained trees.
- There shall be no vehicular or plant (e.g. wood chipper) access within the RPAs of retained trees that are not under hard surfaced areas, as detailed on the TPP.
- Wherever possible the tree works arisings should be retained on site and utilised to form brash and/or timber piles for ecological benefit.
- Where felled material is to be chipped then this is to be used for landscaping mulch, where practicable.
- Where the retention of tree works arisings is not considered to be feasible then these arisings should be removed from the site.
- No services are to be installed below ground level within RPAs.
- No construction related operations should occur within RPAs, unless specifically detailed in the Arboricultural Method Statement.
- No excavation or any other operations should occur within the RPAs, other than as detailed in the Arboricultural Method Statement.
- All construction equipment and materials should be stored outside RPAs.
- Deliveries by crane should be supervised by the Site Manager, positioning the vehicle in such a manner that retained trees are not put at risk of damage.
- No substances with potential to contaminate the soil (e.g. chemicals, concrete washings, diesel, vehicle washings, etc.) should be discharged within 10.0 metres of any tree crown. This should take into consideration the topography of the site in order to avoid materials running towards trees.
- No notice boards, phone cables or services should be attached to any part of any tree.
- A log should be kept of any activity or incident with an impact or potential impact on protected trees and made available at all times for review by the Project Arboriculturist and the Council Tree Officer.

- TEMPORARY PROTECTIVE FENCING SPECIFICATION -

Construction Exclusion Zones (CEZs), shall be enclosed by **Temporary Protective Fencing**. The fencing/ground protection Type(s), locations, and extents shall be agreed, in writing, with the Local Planning Authority (LPA). In turn, the **Temporary Protective Fencing** shall:

1. be constructed as in accordance with the Type 2 or Type 3 'Temporary Protective Fencing Construction' sections as detailed herein and agreed, in advance with the LPA;
2. be retained in place throughout the development process until completion of the project, and only removed following receipt of written permission from the LPA;
3. be sited in the area(s) defined by the Root Protection Areas on the associated Tree Impact Plan, or as the CEZs on the Tree Protection Plan;
4. be erected prior to any construction, demolition or excavation works and remain in place for the duration of the project;
5. precede any delivery of site accommodation and/or materials and/or plant machinery;
6. exclude all construction related activity, with the sole exception of specified arboricultural works and any other works to be carried out under supervision that have been agreed by all parties;
7. exclude the storage of all development related materials and substances including fuels, oils, additives, cement and/or any other deleterious substance; and
8. be affixed with a 600mm x 300mm warning sign reading "TREE PROTECTION AREA KEEP OUT" (see Figure 1, below), at every 10.0 metre length of protective fencing.
9. Important: Any incursion into CEZs must be by prior arrangement, following consultation with the LPA.

Figure 1: CEZ Warning Sign

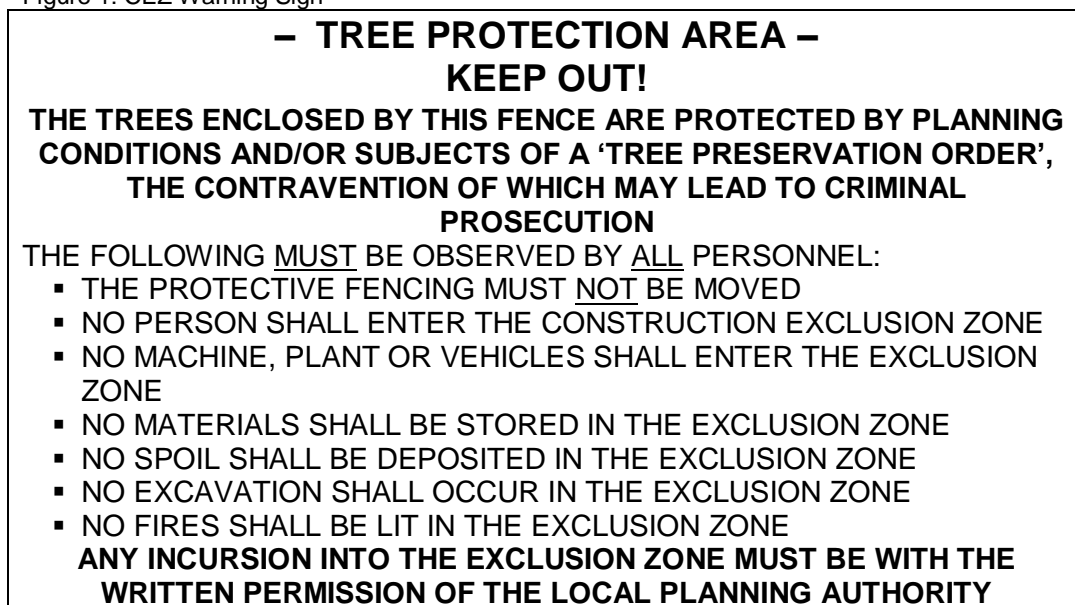

Type 2 Temporary Protective Fencing Construction (see Figure 3(a), below)

1. Temporary protective fencing panels shall be weldmesh "Heras" panels of at least 2.0 metres in height.
2. The panels shall stand on rubber or concrete feet.
3. The panels shall butt together, and be joined together using a minimum of two anti-tamper couplers, installed so that they can only be removed from inside the fence.
4. The distance between the fence couplers shall be at least 1.0 metre, and shall be uniform throughout the fence.
5. The panels shall be supported on the inner side by stabiliser struts, which shall be clamped to the scaffold framework at a 45° angle and extend back into the CEZ and shall be attached to a base plate, which shall be secured to the ground with pins (Figure 3a).
6. No fixing shall be made to any tree and all possible precautions shall be taken to prevent damage to tree roots when locating posts.
7. A 600mm x 300mm warning sign reading "TREE PROTECTION AREA KEEP OUT" (see Figure 1) shall be fixed to every 10.0 metre length of protective fencing.
8. On completion of erection, and prior to any demolition or construction works, site preparation, excavation or delivery of plant and materials, the Consulting Arboriculturist or the LPA Tree Officer, as agreed, shall inspect the Temporary Protective Fencing.

Figure 3(a): Type 2 Fencing (BS5837:2012 above-ground strut stabilising system with ground pins)

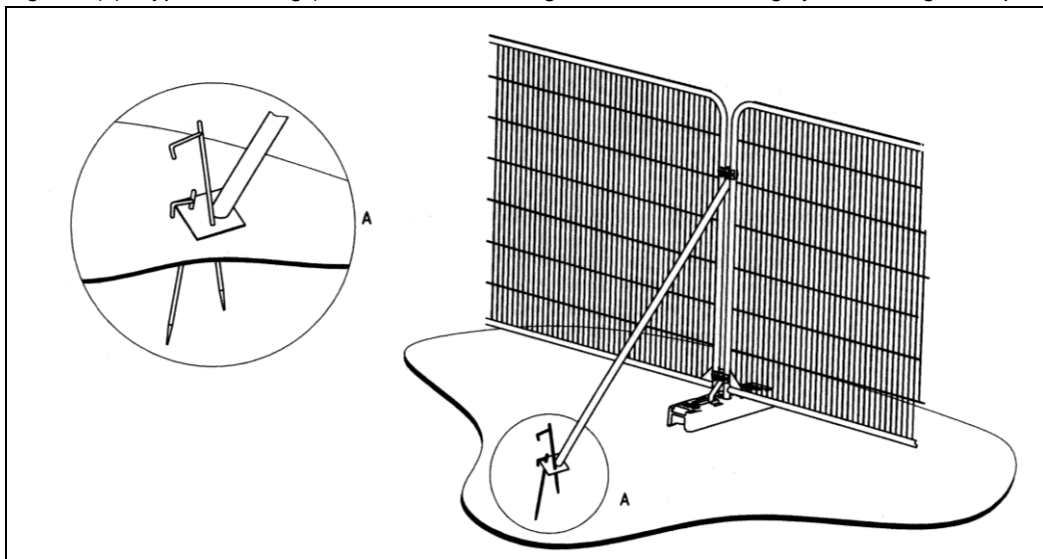

Type 3 Temporary Protective Fencing Construction (see Figure 3(b), overleaf)

1. Temporary protective fencing panels shall be weldmesh "Heras" panels of at least 2.0 metres in height.
2. The panels shall stand on rubber or concrete feet.
3. The panels shall butt together, and be joined together using a minimum of two anti-tamper couplers, installed so that they can only be removed from inside the fence.
4. The distance between the fence couplers shall be at least 1.0 metre, and shall be uniform throughout the fence.
5. The panels shall be supported on the inner side by stabiliser struts, which shall be clamped to the scaffold framework at a 45° angle and extend back into the CEZ and shall be attached to a block tray base (Figure 3b).
6. No fixing shall be made to any tree and all possible precautions shall be taken to prevent damage to tree roots when locating posts.
7. A 600mm x 300mm warning sign reading "TREE PROTECTION AREA KEEP OUT" (see Figure 1) shall be fixed to every 10.0 metre length of protective fencing.
8. On completion of erection, and prior to any demolition or construction works, site preparation, excavation or delivery of plant and materials, the Consulting Arboriculturist or the LPA Tree Officer, as agreed, shall inspect the Temporary Protective Fencing.

Figure 3(b): Type 3 Fencing (BS5837:2012 above-ground stabilising system with strut on block tray)

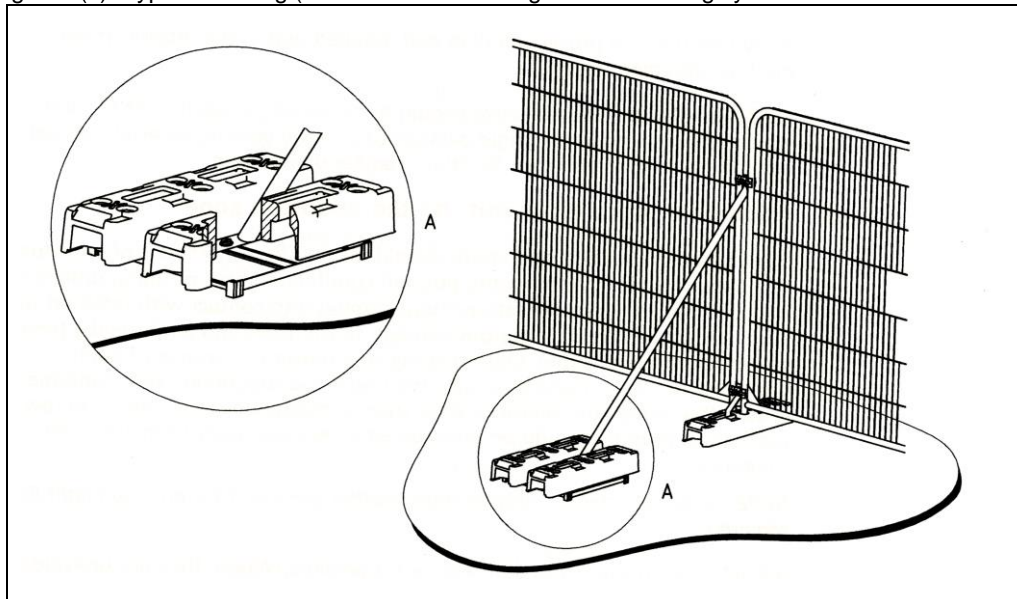

Hedgerow Protective Fencing (see Figure 4 below)

Figure 4 (below): 'Crowd Barrier' type protection for use along hedgerows

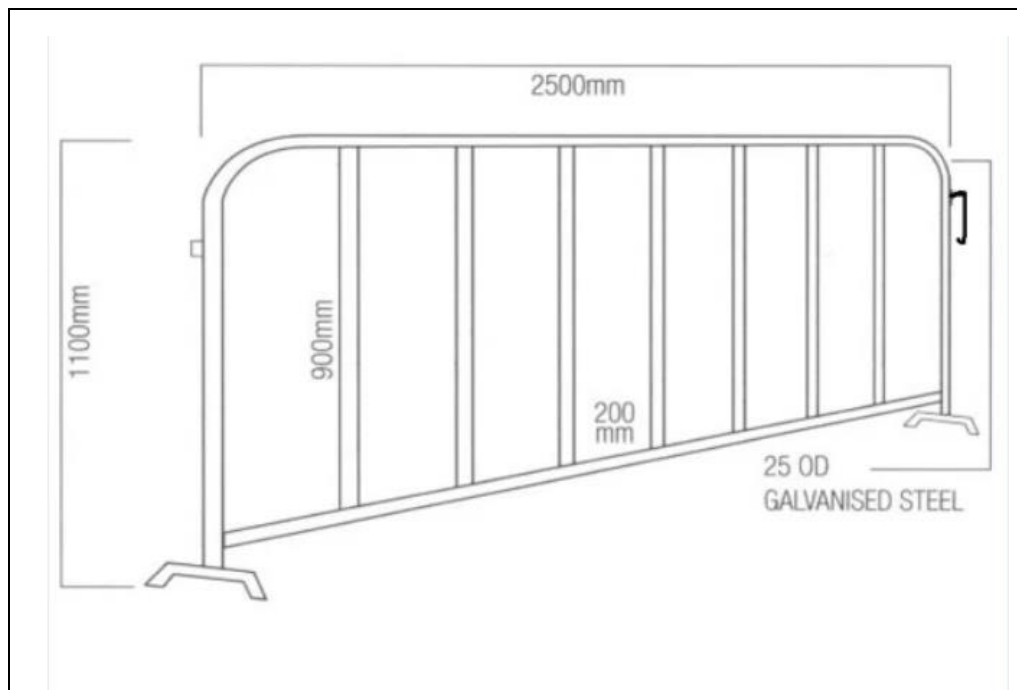

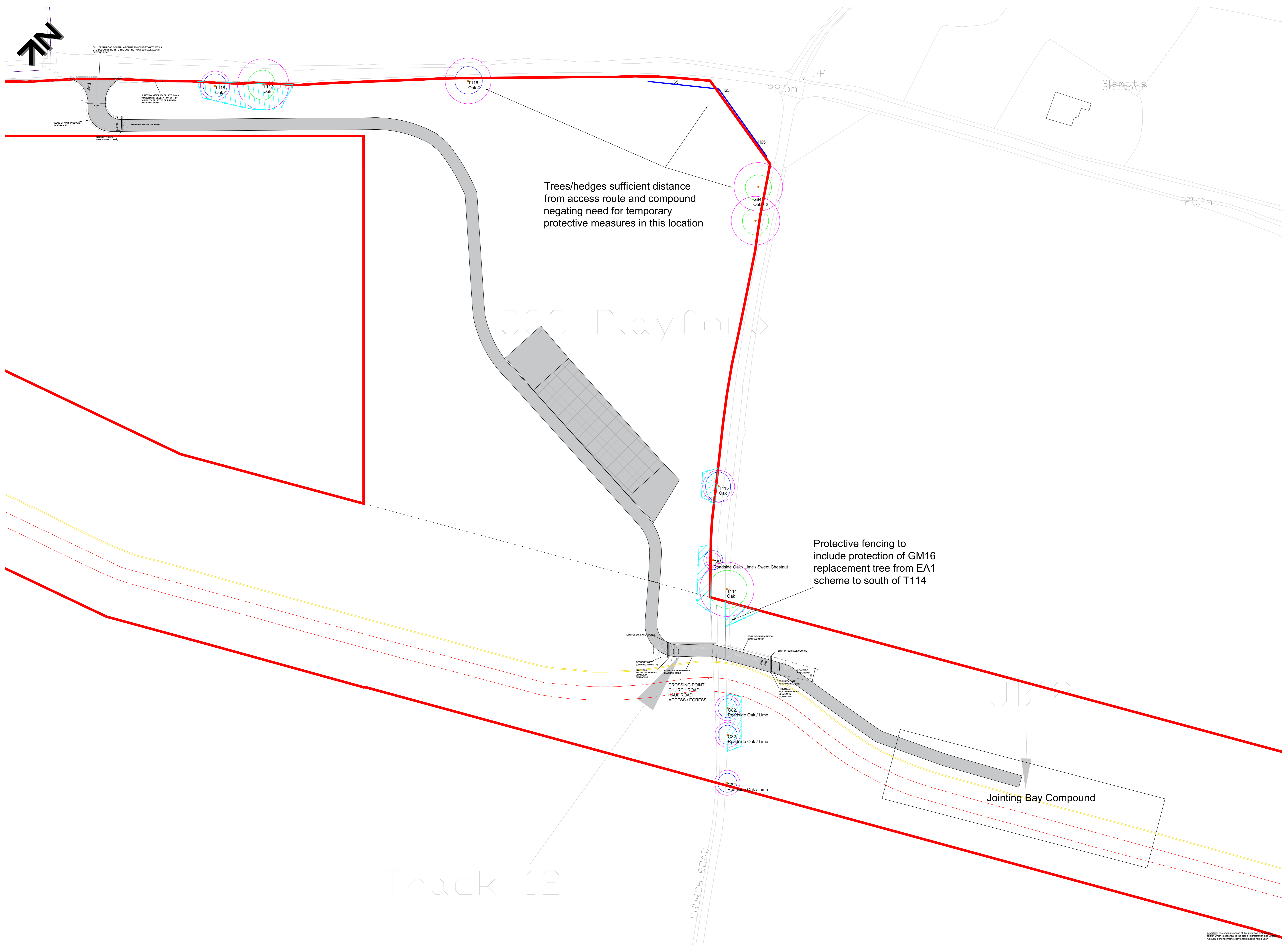

KEY

T = Individual Tree
 G = Group
 H = Hedge

Please refer to associated Arboricultural Method Statement and appendices for specific details in respect of items below.

Tree Categories:

Those to be Considered for Retention:

- Category 'A' Tree/Group/Hedge: Those of a High Quality with an Estimated Remaining Life Expectancy of at Least 40 Years
- Category 'B' Tree/Group/Hedge: Those of a Moderate Quality with an Estimated Remaining Life Expectancy of at Least 20 Years
- Category 'C' Tree/Group/Hedge: Those of a Low Quality with an Estimated Remaining Life Expectancy of at Least 10 Years, or Young Trees

Those Considered Unsuitable for Retention:

- Category 'U' Tree/Group/Hedge: Those in Such a Condition that they Cannot Reliably be Retained as Living Trees in the Control of the Current Land Use for Longer Than 10 Years

Note: The tree and hedge locations were plotted onto the plan from a desk based review using a combination of the provided tree survey data available, the proposed plans supplied by the client (i.e. Scottish Power Renewables) and information on Google Earth. As such, the plotted location of the tree and the location and extent of the hedges, and their corresponding canopy spread and RPA's cannot therefore be considered to be wholly accurate.

Root Protection Areas (RPAs):

RPAs: Areas of Ground Around Trees that should be Protected Throughout Development Works with Protective Fencing to form a Construction Exclusion Zone - see Applicable Temporary Protective Fencing Specification

Construction Exclusion Zones (CEZs):

CEZs: Areas of Ground Around Retained Trees to be Enclosed with Temporary Fencing, with Throughout Development Works. Note: Best Line Represents Positioning of Fencing - see Temporary Protective Fencing Specification

Route of EA3:

Route of EA3 Cable Ducts
 Route of Existing EA1 Cable Ducts

Tree/Group/Hedge Removal Summary

None.

EA1 Replanting Removal Summary

H411F

Project:
 EAST ANGLIA THREE OFF SHORE WIND FARM

Site:
 BUTTS ROAD & HOLLY LANE
 PLAYFORD
 IPSWICH
 SUFFOLK
 IP13 6PH

Client:
 SCOTTISH POWER RENEWABLES

Title:
TREE PROTECTION PLAN
 in Relation to EA3 Cable Route Hub
 (Sheet 1 of 2)

Scale: 1:500@A0
Date: April 2022
Drawn by: JL
Checked by: PH

Bowland Tree Consultancy Ltd
 a wholly owned subsidiary of us
 © 2022 BTCL

Ref: BTCL2203-TPP(P) Rev: D



Replanted section HM18f of EA1
landscape mitigation to be
removed in order to allow EA3
route to pass through

KEY

T = Individual Tree
G = Group
H = Hedge

Please refer to associated Arboricultural Method Statement and appendices for specific details in respect of items below.

Tree Categories:

Those to be Considered for Retention:

- Category 'A' Tree/Group/Hedge: Those of a High Quality with an Estimated Remaining Life Expectancy of at Least 40 Years
- Category 'B' Tree/Group/Hedge: Those of a Medium Quality with an Estimated Remaining Life Expectancy of at Least 20 Years
- Category 'C' Tree/Group/Hedge: Those of a Low Quality with an Estimated Remaining Life Expectancy of at Least 10 Years, or Young Trees

Those Considered Unsuitable for Retention:

- Category 'U' Tree/Group/Hedge: Those in Such a Condition that they Cannot Reasonably be Retained as Living Trees in the Context of the Current Land Use for Longer Than 10 Years

Note: The tree and hedge locations were plotted onto the plan from a desk based review using a combination of the provided tree survey data available, the proposed plans supplied by the client (i.e. Scottish Power Renewables) and information on Google Earth. As such, the plotted location of the tree and the location and extent of the hedges, and their corresponding canopy spread and RPA's cannot therefore be considered to be wholly accurate.

Root Protection Areas (RPAs):

RPA: Areas of Ground Around Trees that should be Protected Throughout Development Works with Protective Fencing to form a Construction Exclusion Zone, and Appropriate Temporary Protective Fencing Specification

Construction Exclusion Zones (CEZs):

CEZ: Areas of Ground Around Retained Trees to be Enclosed with Temporary Fencing, with Through Development Works. Note: Best Line Represents Positioning of Fencing - see Temporary Protective Fencing Specification

Route of EA3:

Estimated Route of EA3

Tree/Group/Hedge Removal Summary

None

EA1 Replanting Removal Summary

HM18f

Project:
EAST ANGLIA THREE OFF SHORE WIND FARM

Site:
BUTTS ROAD & HOLLY LANE PLAYFORD IPSWICH SUFFOLK IP13 6PH

Client:
SCOTTISH POWER RENEWABLES

Title:
TREE PROTECTION PLAN
in Relation to EA3 Cable Route Hubs (Plan 2 of 2)

Scale: 1:500@A0
Date: April 2022
Drawn by: JL
Checked by: PH

Bowland Tree Consultancy Ltd
www.bowlandtreeconsultancy.co.uk
© 2017-2022

Ref: BTC2293-TP(P) Rev: D

33021165 The original version of this plan was produced in Word. Where it is converted to PDF, the text may be slightly different. As such, a photocopyable copy should not be relied upon.

DISCLAIMER

Survey Limitations: Unless otherwise stated all trees are surveyed from ground level using non-invasive techniques. The disclosure of hidden crown and stem defects, in particular where they may be above a reachable height or where trees are ivy clad or in areas of ground vegetation, cannot therefore be expected. All obvious defects, however, are reported. Detailed tree safety appraisals are only carried out under specific written instructions. Comments upon evident tree safety relate to the condition of said tree at the time of the survey only.

Unless otherwise stated all trees should be re-inspected annually in order to appraise their on-going mechanical integrity and physiological condition. It should, however, be recognised that tree condition is subject to change, for example due to the effects of disease, decay, high winds, development works, etc. Changes in land use or site conditions (e.g. development that increases access frequency) and the occurrence of severe weather incidents are also significant considerations with regards tree structural integrity and trees should therefore be re-assessed in the context of such changes and/or incidents and inspected at intervals relative to identified and varying site conditions and associated risks.

Where trees are located wholly or partially on neighbouring private third-party land then said land is not accessed and our inspection is therefore restricted to what can reasonably be seen from within the site. Stem diameters of trees located on such land are estimated. Any subsequent comments and judgments made in respect of such trees are based on these restrictions and are our preliminary opinion only. Recommendations for works to neighbouring third-party trees are only made where a potentially unacceptable risk to persons and/or property has been identified during our survey. Where significant structural defects of third-party trees are identified and associated management works are considered essential to negate any risk of harm and/or damage then we will first attempt to inform the site occupier of the issues and, if not possible, then inform the relevant Council. Where a more detailed assessment is considered necessary then appropriate recommendations are set out in the Tree Survey Schedule.

Where tree stem locations are not included on the plan(s) provided then they are plotted at the time of the survey using, where appropriate and/or practicable, a combination of measurement triangulation and GPS co-ordination. Where this is not possible then locations are estimated. Restrictions in these respects are detailed in the report.

The tree survey and any report information provided is intended as a guide to identify key tree related constraints to site development only. As such, the potential influence of trees upon existing or proposed buildings or other structures resulting from the effects of their roots abstracting water from shrinkable load-bearing soils is not considered herein. The tree survey information in its current form should not therefore be considered sufficient to determine appropriate foundation depths for new buildings. Accordingly, an updated survey, with reference to the current NHBC Standards Chapter 4.2 - Building Near Trees, must therefore be prepared for the specific purpose of informing suitable foundation depths subsequent to planning approval being granted. The advice of a structural engineer must also be sought with regard to appropriate foundation depths for new buildings.

Copyright & Non-Disclosure Notice: The content and layout of this report are subject to copyright owned by Bowland Tree Consultancy Ltd, save to the extent that copyright has been legally assigned to us by another party or is used by Bowland Tree Consultancy Ltd under license. This report may not be copied or used without our prior written agreement for any purpose other than those indicated.

Third Parties: Any disclosure of this document to a third party is subject to this disclaimer. The report was prepared by Bowland Tree Consultancy Ltd at the instruction of and for use by our client, as named. This report does not in any way constitute advice to any third party who is able to access it by any means. Bowland Tree Consultancy Ltd excludes to the fullest extent lawfully permitted all liability whatsoever for any loss or damage arising from reliance on the contents of this report.

Statutory Tree Protection: It is the client's responsibility to check for the presence of any statutory tree protection measures, such as the site's location within a Conservation Area and/or the presence of any Tree Preservation Orders, directly with the applicable Council's planning department prior to scheduling or carrying out any tree works. In turn, it is also the client's responsibility to check for the need for a felling licence with the Forestry Commission prior to scheduling or carrying out any tree works. Bowland Tree Consultancy Ltd cannot be held responsible for any decisions made by the client to prune or remove trees where any such statutory protection exists.

APPENDIX 2 PLAYFORD LANDSCAPE MITIGATION PLANS AND SCHEDULE

FOR DISCHARGE

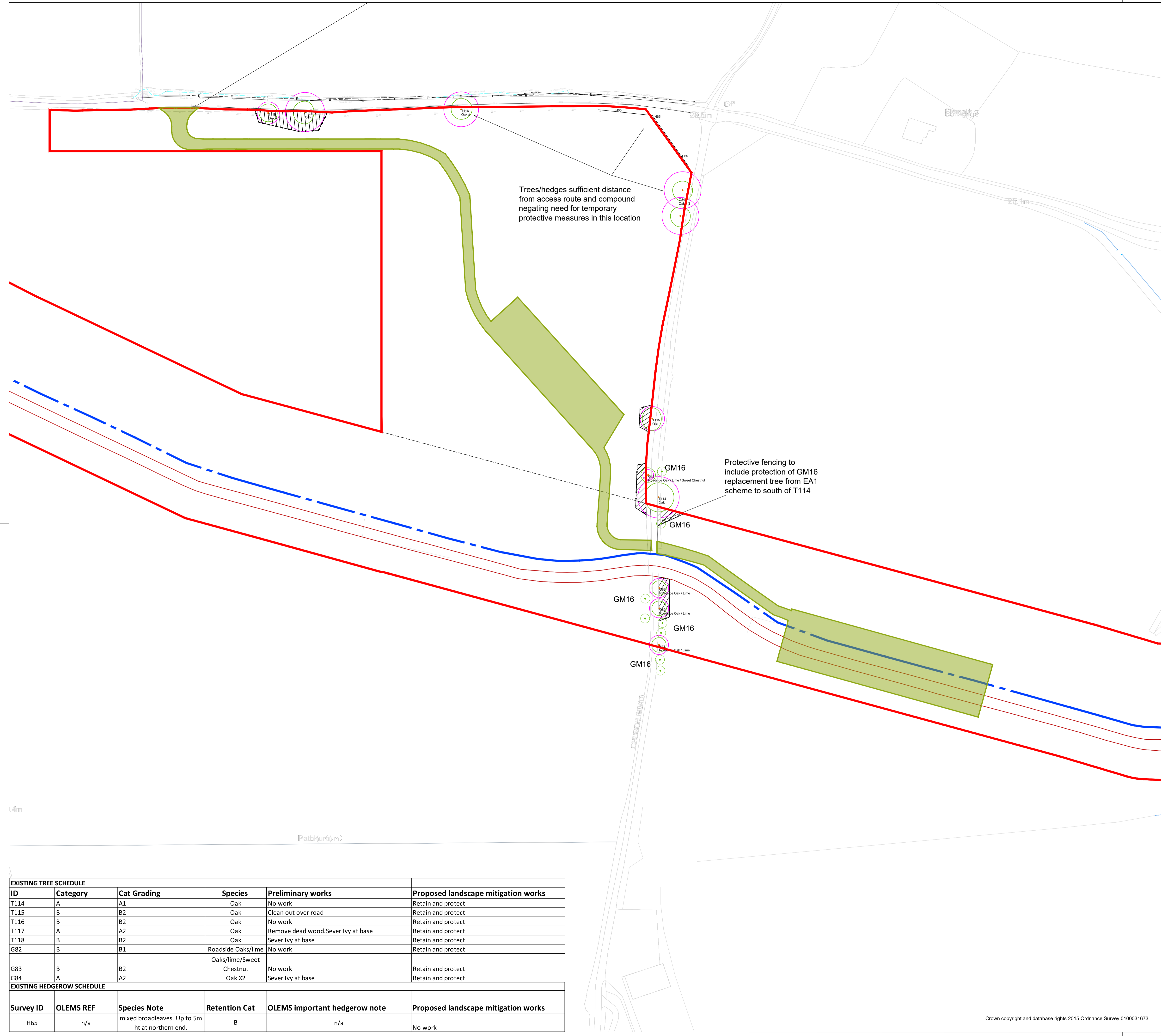

LEGEND

- EA1 / EA3 DCO Boundary
- EA3 Cable Route
- EA1 Cable Route
- Access point locations
- Haul road route
- Access Track / Trackway (temporary access route during works) Indicative route shown. Trackway to follow previous agreed EA1 route where possible.
- Existing Tree (Refer to Bowland Arboricultural Statement for further details. EA3-OND-CNS-REP-IBR-000002 (PCCS Playford))
- Tree Root Protection Area (Refer to Bowland Arboricultural Statement for further details. EA3-OND-CNS-REP-IBR-000002 (PCCS Playford))
- Existing Hedgerow (Refer to Bowland Arboricultural Statement for further details. EA3-OND-CNS-REP-IBR-000002 (PCCS Playford))
- Tree Protection Fencing (Refer to Bowland Arboricultural Statement for further details. EA3-OND-CNS-REP-IBR-000002 (PCCS Playford))

Tree protection fencing as per BS 5837: 2012 for all trees to be retained / Hedgerows to be protected by steel crowd barriers. Refer to Appendices 4: EA3-LDC-CNS-DRG-IBR-000006 and 5: EA3-LDC-CNS-BOM-IBR-000004 for fencing details. TBC on site in agreement with landowner and ecologist.

LANDSCAPE MITIGATION MEASURES

- Hedgerow removal and replacement planting (Refer to Appendix 3: EA3-LDC-CNS-BOM-IBR-000003 for details of species mix. TBC on site in agreement with landowner and ecologist.)
- Grass Seeded Area (Refer to Appendix 3: EA3-LDC-CNS-BOM-IBR-000003 for details of species mix. TBC on site in agreement with landowner and ecologist.)

NOTES

- This drawing is to be read in conjunction with all other drawings and specifications.
- Do not scale off this drawing. Written dimensions to be taken only.
- Any discrepancies found between this drawing and other drawings and specifications in the construction documents must be referred to the Landscape Architect prior to work commencing.
- This drawing must not be copied in whole or in part without prior written consent of Optimised Environments Ltd.

DRAWING INFORMATION BASED UPON

Emapsite: © Crown copyright and database rights 2019 Ordnance Survey 0100031673.

OS OpenData: Contains OS data © Crown copyright and database right (2019).

Google Earth: Please show the attribution statement shown on the Google map or image that you are using.

Topographical Survey: Please reference surveyor's survey.

CDM INFORMATION

- To be completed

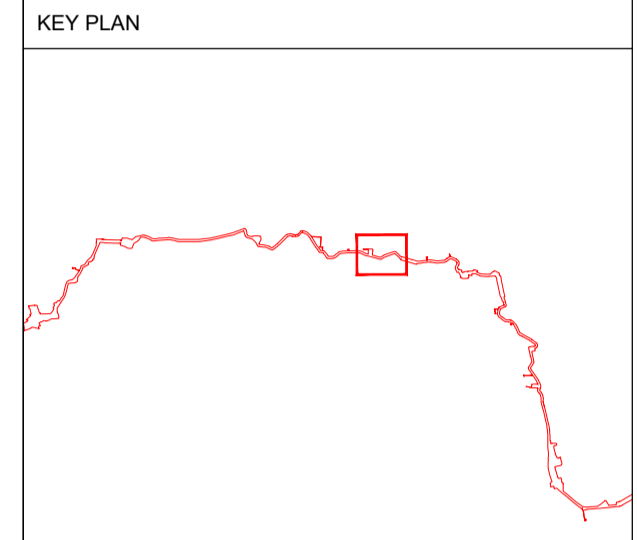

CHECKED	APPROVED
---------	----------

Issue	Revision	Initial	Date
03	Access routes amended. SPR comments. Updated Arboriculture drawings.	rt	12.04.22
02		rt	28.01.22
01	Access routes amended. Drawing legend. Draft issue for comments.	rt	10.01.22
00		rt	16.12.21

open optimised environments

optimised environments ltd
 EDINBURGH 2nd Floor | Quarter Mile Two | 2 Lister Square | Edinburgh | EH3 9SL
 0131 221 9920 | optimisedenvironments.com

LONDON 107-111 Fleet Street | London | EC4A 3AB
 0203 984 4032 | optimisedenvironments.com

MANCHESTER 13 Swan Street | Manchester | M4 6JJ
 0161 696 7550 | optimisedenvironments.com

Client
ScottishPower Renewables

Project
East Anglia THREE Offshore Windfarm

Drawing Title
PLAYFORD Appendix 2 LANDSCAPE MITIGATION PLAN Sheet 1 of 2

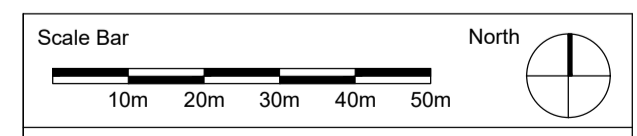

Scale: 1:1000@A1 Date: DECEMBER 2021
 By: RT Status: For Information
 Checked: JD Approved: LT

Drawing Number
EA3-LDC-CNS-DRG-IBR-000004 Rev **03**

Computer File: P:\2020\01527_EA3\plant\CAD\AUTOCAD\SHEETS

ID	Category	Cat Grading	Species	Preliminary works	Proposed landscape mitigation works
T114	A	A1	Oak	No work	Retain and protect
T115	B	B2	Oak	Clean out over road	Retain and protect
T116	B	B2	Oak	No work	Retain and protect
T117	A	A2	Oak	Remove dead wood. Sever Ivy at base	Retain and protect
T118	B	B2	Oak	Sever Ivy at base	Retain and protect
G82	B	B1	Roadside Oaks/lime	No work	Retain and protect
G83	B	B2	Oaks/lime/Sweet Chestnut	No work	Retain and protect
G84	A	A2	Oak X2	Sever Ivy at base	Retain and protect

Survey ID	OLEMS REF	Species Note	Retention Cat	OLEMS important hedgerow note	Proposed landscape mitigation works
H65	n/a	mixed broadleaves. Up to 5m ht at northern end.	B	n/a	No work

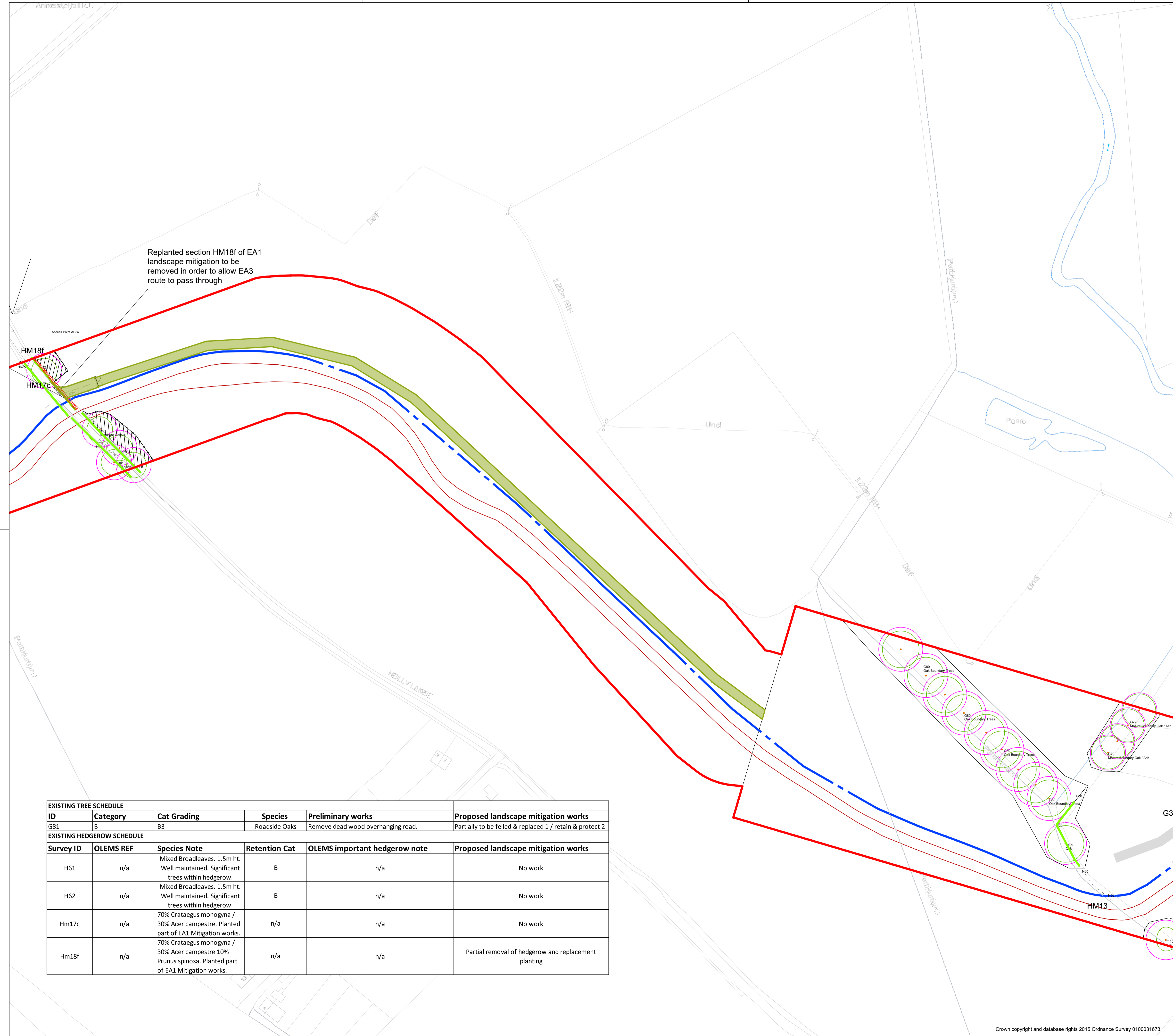

- LEGEND**
- EA1 / EA3 DCO Boundary
 - EA3 Cable Route
 - EA1 Cable Route
 - Access point locations
 - Haul road route
 - Access Track / Trackway (temporary access route during works) Indicative route shown. Trackway to follow previous agreed EA1 route where possible.
 - Existing Tree (Refer to Bowland Arboricultural Statement for further details. EA3-OND-CNS-REP-IBR-000002 (PCCS Playford))
 - Tree Root Protection Area (Refer to Bowland Arboricultural Statement for further details. EA3-OND-CNS-REP-IBR-000002 (PCCS Playford))
 - Existing Hedgerow (Refer to Bowland Arboricultural Statement for further details. EA3-OND-CNS-REP-IBR-000002 (PCCS Playford))
 - Tree Protection Fencing (Refer to Bowland Arboricultural Statement for further details. EA3-OND-CNS-REP-IBR-000002 (PCCS Playford))
- Tree protection fencing as per BS 5837: 2012 for all trees to be retained / Hedgerows to be protected by steel crowd barriers. Refer to Appendices 4: EA3-LDC-CNS-DRG-IBR-000006 and 5: EA3-LDC-CNS-BOM-IBR-000004 for fencing details. TBC on site in agreement with landowner and ecologist.

- LANDSCAPE MITIGATION MEASURES**
- Hedgerow removal and replacement planting (Refer to Appendix 3: EA3-LDC-CNS-BOM-IBR-000003 for details of species mix. TBC on site in agreement with landowner and ecologist.)
 - Grass Seeded Area (Refer to Appendix 3: EA3-LDC-CNS-BOM-IBR-000003 for details of species mix. TBC on site in agreement with landowner and ecologist.)

- NOTES**
- This drawing is to be read in conjunction with all other drawings and specifications.
 - Do not scale off this drawing. Written dimensions to be taken only.
 - Any discrepancies found between this drawing and other drawings and specifications in the construction documents must be referred to the Landscape Architect prior to work commencing.
 - This drawing must not be copied in whole or in part without prior written consent of Optimised Environments Ltd.

DRAWING INFORMATION BASED UPON

Emapsite: © Crown copyright and database rights 2019 Ordnance Survey 0100031673.

OS OpenData: Contains OS data © Crown copyright and database right (2019).

Google Earth: Please show the attribution statement shown on the Google map or image that you are using.

Topographical Survey: Please reference surveyor's survey.

CDM INFORMATION

- To be completed

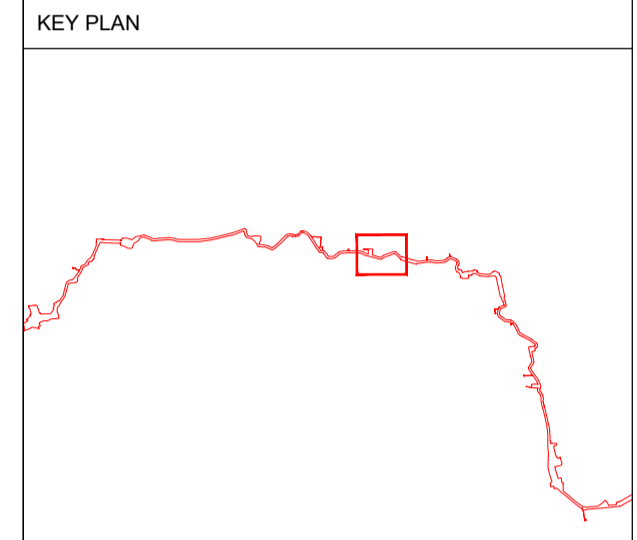

Issue	Revision	Initial	Date
03	Access routes amended.	rt	12.04.22
02	SPR comments. Updated Arboriculture drawings.	rt	28.01.22
01	Access routes amended. Drawing legend.	rt	10.01.22
00	Draft issue for comments.	rt	16.12.21

open optimised environments

optimised environments ltd
 2nd Floor | Quarter 2 | 2 Laser Square | Edinburgh | EH3 9SL
 0131 221 9920 | optimisedenvironments.com

LONDON
 107-111 Fleet Street | London | EC4A 3AB
 0203 984 4032 | optimisedenvironments.com

MANCHESTER
 13 Swan Street | Manchester | M4 6JJ
 0161 696 7550 | optimisedenvironments.com

Client
ScottishPower Renewables

Project
East Anglia THREE Offshore Windfarm

Drawing Title
PLAYFORD Appendix 2 LANDSCAPE MITIGATION PLAN Sheet 2 of 2

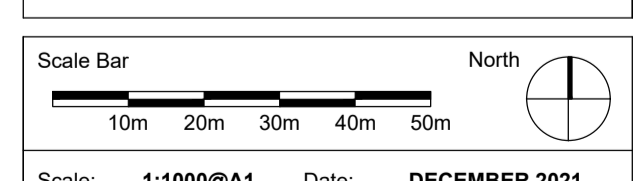

Scale: 1:1000@A1 Date: DECEMBER 2021
 By: RT Status: For Information
 Checked: JD Approved: LT

Drawing Number
EA3-LDC-CNS-DRG-IBR-000005 03

Computer File: P:\2020\01527_EA3\plan\CAD\AUTOCAD\SHEETS

EXISTING TREE SCHEDULE					
ID	Category	Cat Grading	Species	Preliminary works	Proposed landscape mitigation works
G81	B	B3	Roadside Oaks	Remove dead wood overhanging road.	Partially to be felled & replaced 1 / retain & protect 2

EXISTING HEDGEROW SCHEDULE					
Survey ID	OLEMS REF	Species Note	Retention Cat	OLEMS important hedgerow note	Proposed landscape mitigation works
H61	n/a	Mixed Broadleaves. 1.5m ht. Well maintained. Significant trees within hedgerow.	B	n/a	No work
H62	n/a	Mixed Broadleaves. 1.5m ht. Well maintained. Significant trees within hedgerow.	B	n/a	No work
Hm17c	n/a	70% Crataegus monogyna / 30% Acer campestre. Planted part of EA1 Mitigation works.	n/a	n/a	No work
Hm18f	n/a	70% Crataegus monogyna / 30% Acer campestre 10% Prunus spinosa. Planted part of EA1 Mitigation works.	n/a	n/a	Partial removal of hedgerow and replacement planting

APPENDIX 3 HEDGEROWS & GRASSES PLANTING SCHEDULES (EA3-LDC-CNS-BOM-IBR-000004)

FOR DISCHARGE

HM: Native Hedgerow Mix

Planting specification:

Species and mix: As per table below

Planting: Plant 300mm centres, in a double staggered row, 300mm between rows. Cut back hard after planting to encourage base growth. Refer to plan and section drawings (below) for typical planting details

Root Treatment: Provide mycorrhizal inoculant for each plant at planting. Planting must include water retaining granules.

Weed suppression: For the length of the hedge trench provide 50mm deep well composted bark mulch, 500mm either side of hedge trench.

Protection: For each plant, provide a transparent spiral guard 90cm plus single bamboo cane.

Watering: Water at planting to full rooting depth. If addition of bark mulch delayed, only apply bark mulch after rain or watering. During periods of drought in establishment phase undertake heavy watering to full rooting depth.

General Maintenance:

Mechanical trimming in full A shape. Trim sections of hedge on 3 year rotation in winter.

Weed control by hand weeding/hoeing only in May & September
NO herbicide applications required.

NO fertiliser required.

Review at end of growing season and replace failures as required with appropriately sized plants.

HM Bespoke Hedgerow Mixes (%)														
Note: all plants will be bare root supplied. Specification: 1 + 2; Transplant - seed raised, branched; 5 breaks. Height: 80-100cm														
Hedgerow Mitigation Reference	Crataegus monogyna	Acer campestre	Prunus spinosa	Cornus sanguinea	Euonymus europaeus	Alnus glutinosa	Prunus avium	Sambucus nigra	Corylus avellana	Rosa canina	Quercus robur	Salix caprea	Malus sylvestris	Prunus cerasifera
HM16f	70	20	10	--	--	--	--	--	--	--	--	--	--	--

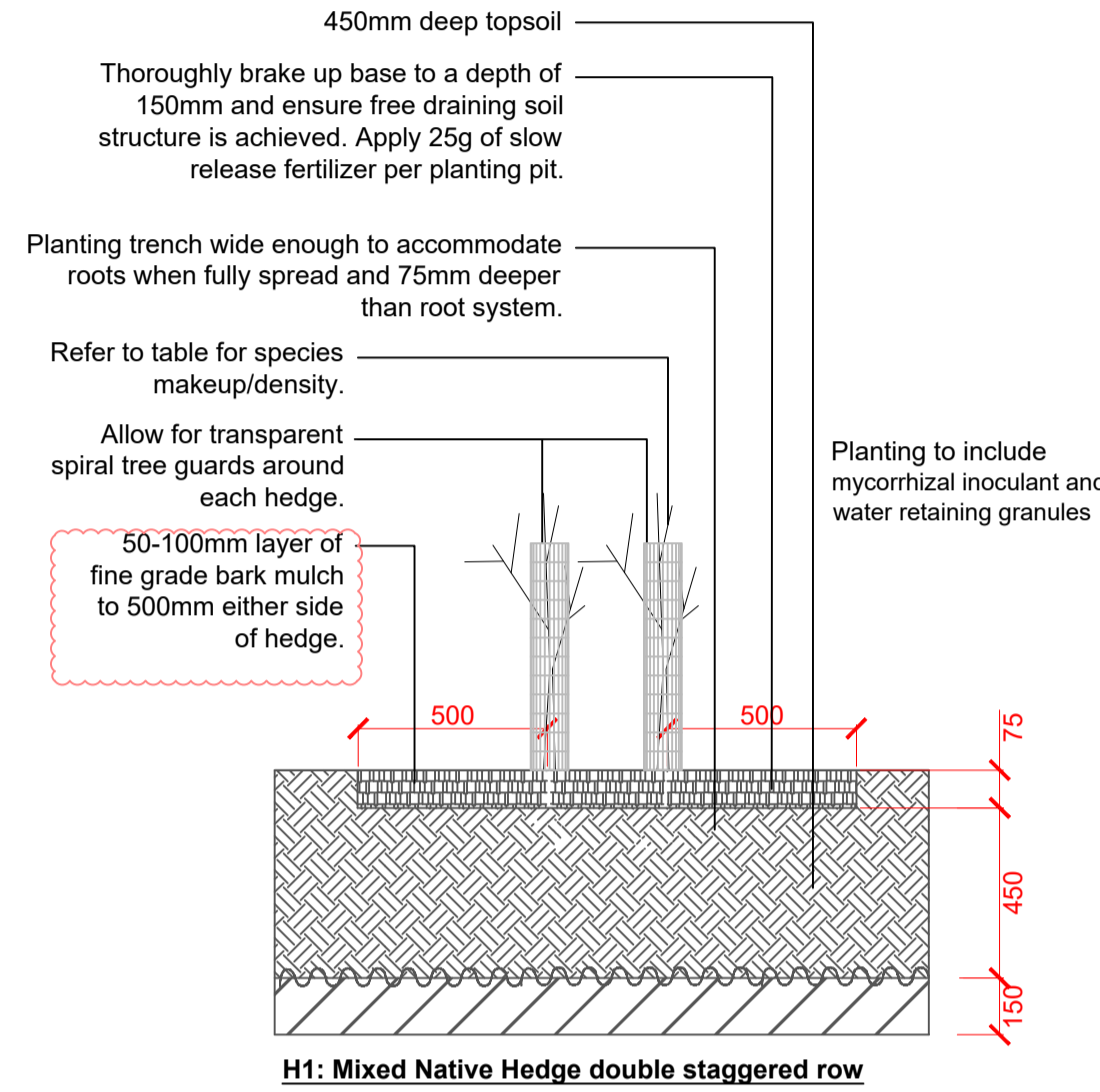

H1: Mixed Native Hedge double staggered row

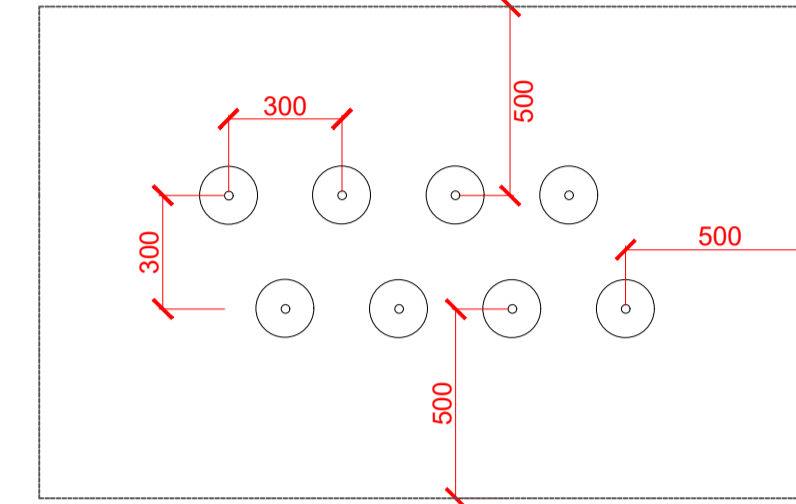

Typical Planting Spacing Arrangement for Mixed Native Hedge.

Spiral shelter for hedge plants

Product: Spiral Shelter

Supplier: Fiberweb Geosynthetics Ltd, or similar approved.
Blackwater Trading Estate,
The Causeway,
MALDON,
CM9 4GG
Tel: +44 (0) 1621 874201

Material: 100% Recycled Photodegradable PVC

Colour: Transparent

Size: 60cm x 50mm

Support: Bamboo cane

HM Bespoke Hedgerow Mix

Scale: 1 : 20

HM Hedge Typical Detail

Scale: 1 : 20

G1: Improved Grassland Mix (also used for Private road verges)

Supplier: Germinal Seeds GB (Formerly British Seed Houses) or similar approved
Camp Road
Witham St. Hughes
Lincoln
LN6 9QJ
Tel: 01522 868714

Product reference: Bespoke mix.

Sowing rate: 5g/m2. Sow between August to October.

E15: Public road verge mix

Supplier: Barenbrug UK or similar approved
33 Perkins Road
Rougham Industrial Estate
Bury St Edmunds
Suffolk
IP30 9ND
Tel: 01359 272000

Product reference: E15 Road verge

Sowing rate: 10-20g/m2. Sow between August to October.

Species	Common Name	% Mix
Festuca brevipila	Hard Fescue	30
Lolium perenne	Perennial Ryegrass	25
Festuca rubra rubra	Strong Creeping Red Fescue	20
Poa pratensis	Smooth Stalked Meadow Grass	10
Agrostis capillaris	Browntop Bent	10
Trifolium repens	White Clover	5
Total		100

G4: Grass for Long Term Topsoil Storage

Supplier: Germinal Seeds GB (Formerly British Seed Houses), or similar approved.
Camp Road
Witham St. Hughes
Lincoln
LN6 9QJ
Tel: 01522 868714

Product reference: A17 (Legume and Clover)

Sowing rate: 2.5g/m2.

Species	Common Name	% Mix
Vicia sativa	Common Vetch	25%
Lotus corniculatus	Birdsfoot Trefoil	15%
Medicago sativa	Lucerne	15%
Trifolium pretense	Red Clover	15%
Onobrychis vicifolia	Sainfoin	15%
Trifolium repens	White Clover	15%
Total		100%

After grading reduce seed bed (25mm deep) to fine, firm tilth with good crumb structure. Rake to a true, even surface, friable and lightly firmed but not over compacted. Remove surface stones/earth clods exceeding 100mm.

Seed mix, refer to accompanying table for species and sowing rate
Minimum 150mm deep topsoil. Refer to Landscape Architect's landscape specification for further information.

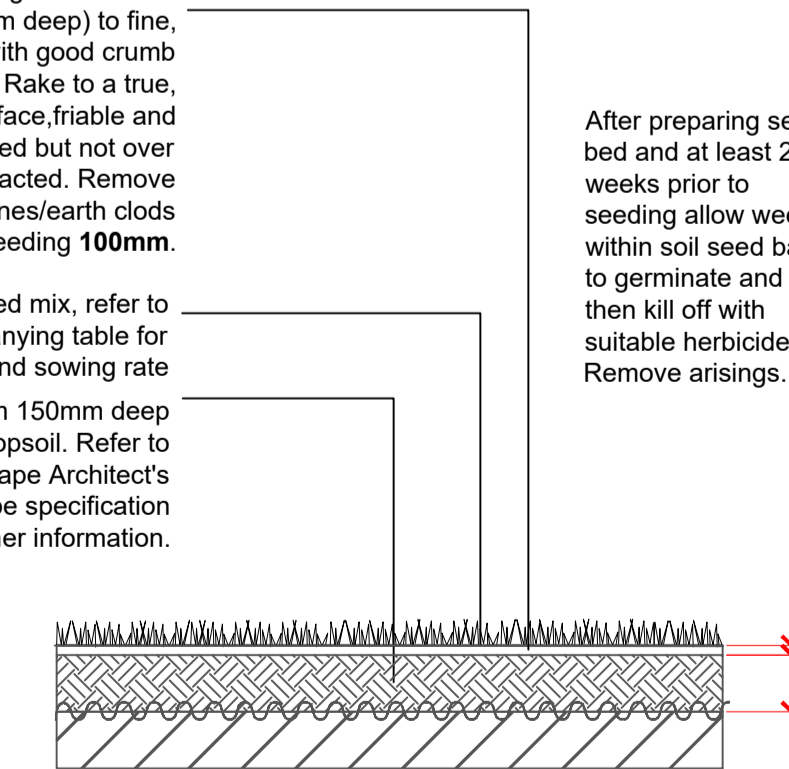

Planting type: G1 and E15 grass seeding

After preparing seed bed and at least 2 weeks prior to seeding allow weeds within soil seed bank to germinate and then kill off with suitable herbicide. Remove arisings.

G1 Improved Grassland Mix

Scale: 1 : 20

E15 Public Road Verge Mix

Scale: 1 : 20

G4 Grass for Long Term Topsoil Storage

Scale: 1 : 20

NOTES

- This drawing is to be read in conjunction with all other drawings and specifications.
- Do not scale off this drawing. Written dimensions to be taken only.
- Any discrepancies found between this drawing and other drawings and specifications in the construction documents must be referred to the Landscape Architect prior to work commencing.
- This drawing must not be copied in whole or in part without prior written consent of Optimised Environments Ltd.

DRAWING INFORMATION BASED UPON

Emapsite: © Crown copyright and database rights 2019 Ordnance Survey 0100031673.

OS OpenData: Contains OS data © Crown copyright and database right (2019).

Google Earth: Please show the attribution statement shown on the Google map or image that you are using.

Topographical Survey: Please reference surveyor's survey.

CDM INFORMATION

KEY PLAN

Issue	Revision	Initial	Date
02	SPR comments. Dandelion omitted from G1 mix	jd	27.01.2022
01	E15 mix added. General text amendments.	rt	10.01.22
00	Draft Issue for comments	rt	16.12.21

open
optimised environments

EDINBURGH 2nd Floor | Quarmite Two | 2 Lister Square | Edinburgh | EH3 9GL
t 0131 221 8500 | e optimisedenvironments.com
LONDON 407/111 Finsbury Street | London | EC2A 3BB
t 0203 984 4022 | e optimisedenvironments.com
MANCHESTER 13 Swan Street | Manchester | M4 5JZ
t 0161 696 7500 | e optimisedenvironments.com

Client
ScottishPower Renewables

Project
East Anglia THREE Offshore Windfarm

Drawing Title
PLAYFORD APPENDIX 3: Planting Schedules / Details Hedgerows & Grasses

Scale Bar North

Scale: 1:20@A1 Date: December 2021

By: rt Status: INFORMATION

Checked: jd Approved: It

Drawing Number
E15-LDC-CNS-BOM-IBR-000002 Rev
02

APPENDIX 4 FENCING DETAILS (EA3-LDC-CNS-BOM-IBR-000003)

FOR DISCHARGE

F4a: Typical construction detail - Nailed post and four rail fence

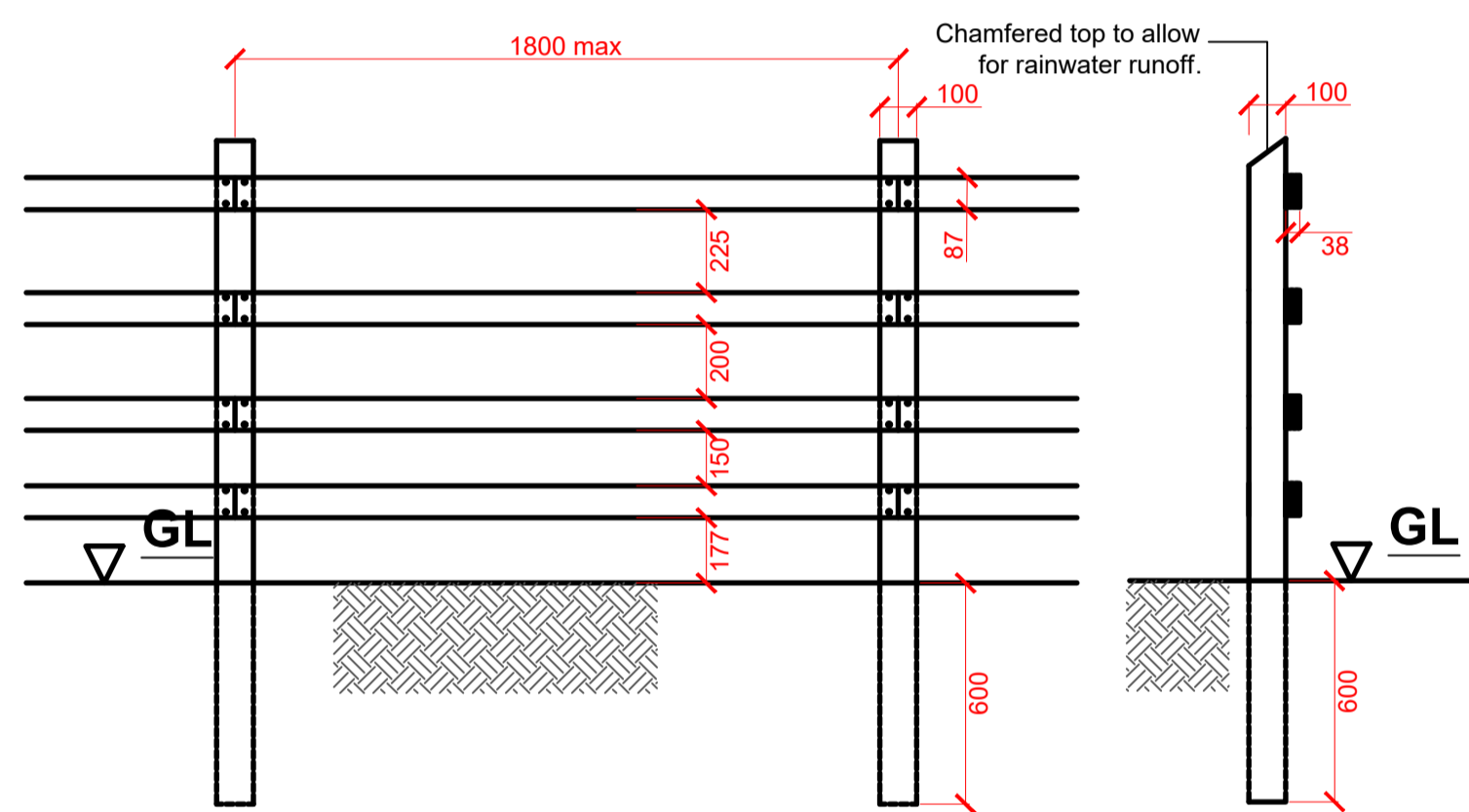

NOTES:

1. BS 1722 Part 7 applies
2. Fencing to follow the ground profile with small adjustments to height as necessary to obtain flowing alignment.
3. All timber shall be FSC pressure treated larch or other softwood as approved. Posts to have chamfered top to shed rainwater.
4. Posts to be 100 x 100 x 1800 set in 600mm deep.
5. Rails to be 38mm x 87mm
6. Nails to be 4mm x 100mm galvanised to BS EN ISO 1461
7. Main posts to be set at intervals no greater than 1.8m
8. Posts to be driven.
9. Rails to be fixed to private side where fence forms boundary between adjoining land ownerships.
10. Rails to be butt jointed in the centre of the posts. No split ends caused by nailing shall be permitted.
13. Conformity: Submit manufacturer's and installer's certificates, to BS 1722-7.

F4a
sheet 000002
Nailed Post and Four Rail Fence
Scale: 1 : 20

F4b Typical construction detail - Post and strained wire fence

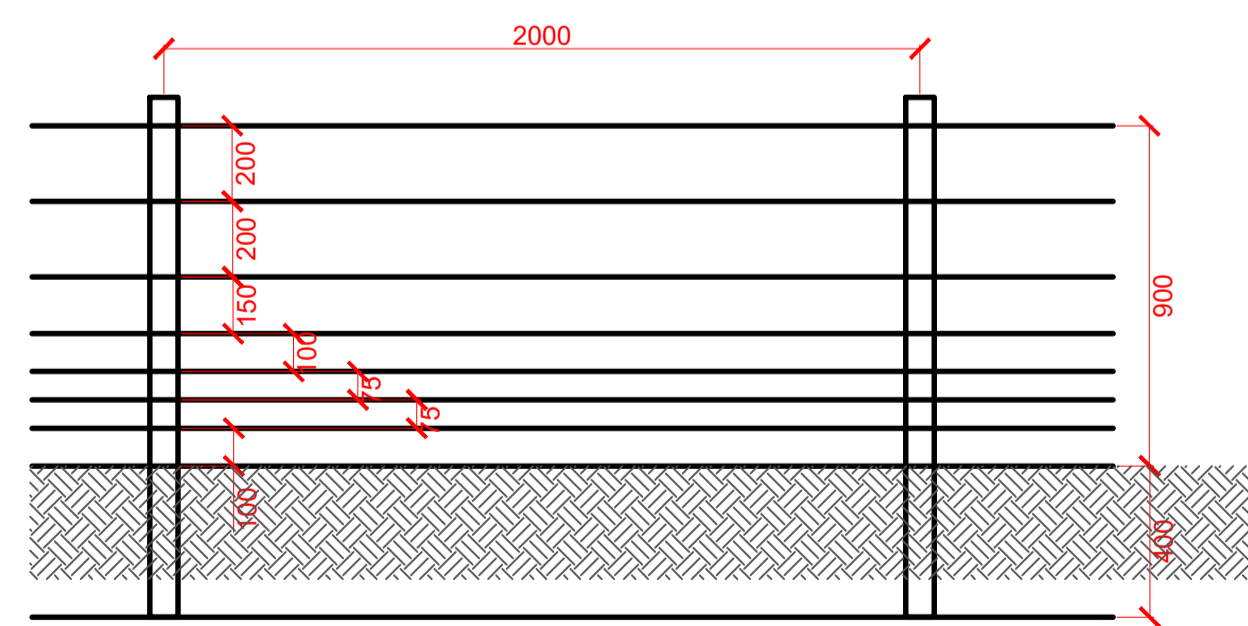

NOTES:

1. BS 1722-2, type SW 90 applies.
2. Fencing to follow the ground profile with small adjustments to height as necessary to obtain flowing alignment.
3. All timber shall be FSC pressure treated larch or other softwood as approved. Posts to have chamfered top to shed rainwater.
4. Intermediate posts to be set at intervals no greater than 2m
5. Straining posts: 450 mm square or 300 mm diameter holes, 600 mm deep filled to two thirds depth with concrete.
6. Struts: 300 x 450 mm holes, 450 mm deep filled to not less than half the depth with concrete.
7. Intermediate posts: Minimum 75 mm surround or 300 mm diameter holes, 600 mm deep filled to not less than half the depth with concrete.
8. Wire and staple fixings to be carbon steel wire, 4 mm diameter, finish: Hot dip galvanized to BS EN ISO 1461
9. Height: 900mm top wire.
10. Wire spacings: 7 wires - spacings vary 200mm/200mm/150mm/100mm/75mm/75mm from top
11. Maximum centres of posts: Straining posts: max 150m in straight runs and at all ends, corners, changes of direction and acute variations in level. Intermediate posts: 2 m.
12. Accessories: Additional mesh - wildlife netting as per F4d.
13. Conformity: Submit manufacturer's and installer's certificates, to BS 1722-2.

F4b
sheet 000002
Post and Strained Wire Fence
Scale: 1 : 20

F4d: Typical construction detail - Rabbit proof fence detail used with F4a fences and as illustrated on details F3a/F3b/F3c/F4c

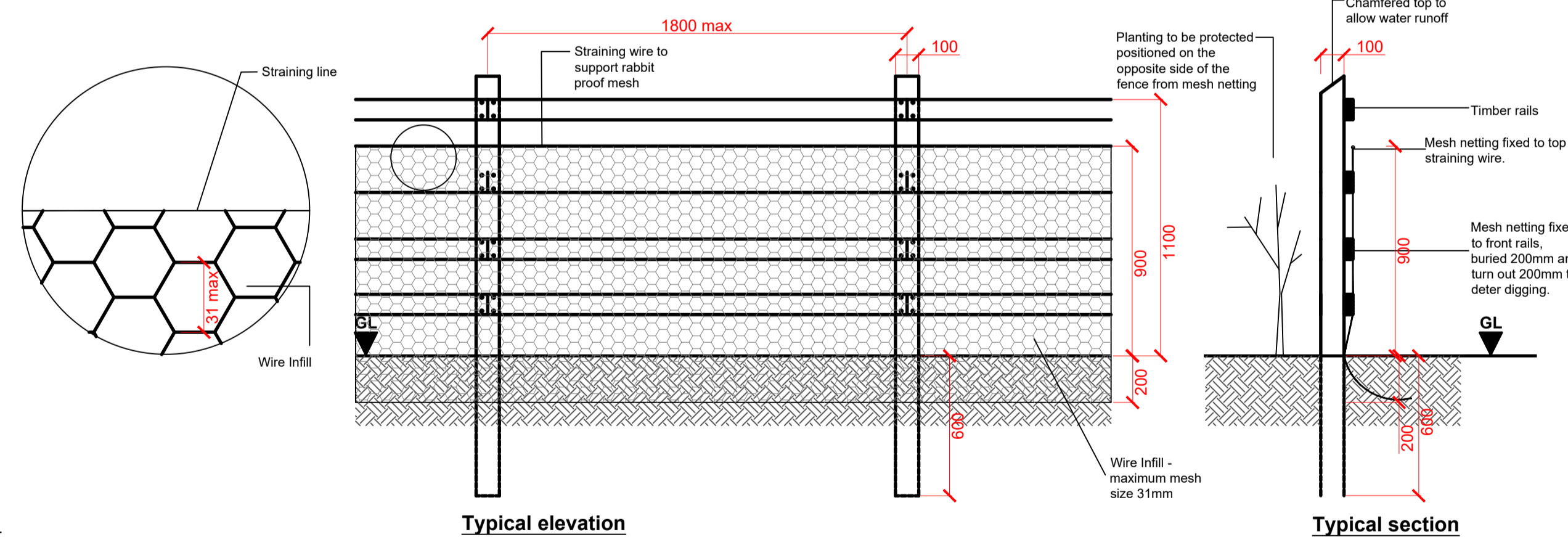

Typical elevation

Typical section

F4d Timber Post and Strained Wire Fencing
ADDITIONAL MESH/ FABRIC: RABBIT NETTING
Manufacturer: Contractor's choice.
Product reference: Contractor's choice
Type: Galvanized hexagonal wire mesh 18 guage/1.2mm diameter.
Colour: Not applicable.
Mesh size: 25 mm (31mm maximum mesh size) as per BS EN 10223-2
Height: 900 mm.
Bottom of mesh: Buried 200 mm deep and turned out 200 mm.
Fixings: Nailed or stapled to wooden posts and rails at 1 m centres.

F4d
sheet 000002
Rabbit Proof Fence
Scale: 1 : 20

NOTES

1. This drawing is to be read in conjunction with all other drawings and specifications.
2. Do not scale off this drawing. Written dimensions to be taken only.
3. Any discrepancies found between this drawing and other drawings and specifications in the construction documents must be referred to the Landscape Architect prior to work commencing.
4. This drawing must not be copied in whole or in part without prior written consent of Optimised Environments Ltd.

DRAWING INFORMATION BASED UPON

Emapsite: © Crown copyright and database rights 2019 Ordnance Survey 0100031673.

OS OpenData: Contains OS data © Crown copyright and database right (2019).

Google Earth: Please show the attribution statement shown on the Google map or image that you are using.

Topographical Survey: Please reference surveyor's survey.

CDM INFORMATION

KEY PLAN

Issue	Revision	Initial	Date
02	SPR comments, F4b added, F3 gates omitted, Annotation amended, Draft issue for comments	jd	27.01.2022
01		rt	10.01.22
00		rt	16.12.21

open
optimised environments

optimised environments ltd
EDINBURGH 2nd Floor | Quaterme Two | 2 Lister Square | Edinburgh | EH3 9GL
LONDON 201111 First Street | London | EC4A 3DF
MANCHESTER 13 Swan Street | Manchester | M4 5JZ

Client
ScottishPower Renewables

Project
East Anglia THREE Offshore Windfarm

Drawing Title
APPENDIX 4
Typical Details - Fencing

Scale Bar	North
Scale: 1:20@A1	Date: December 2021
By: rt	Status: INFORMATION
Checked: jd	Approved: It

Drawing Number
EA3-LDC-CNS-DRG-IBR-000007 Rev **02**

**APPENDIX 5 TYPICAL DETAILS FOR TREE AND HEDGEROW PROTECTIVE FENCING
(EA3-LDC-CNS-DRG-IBR-000006)**

FOR DISCHARGE

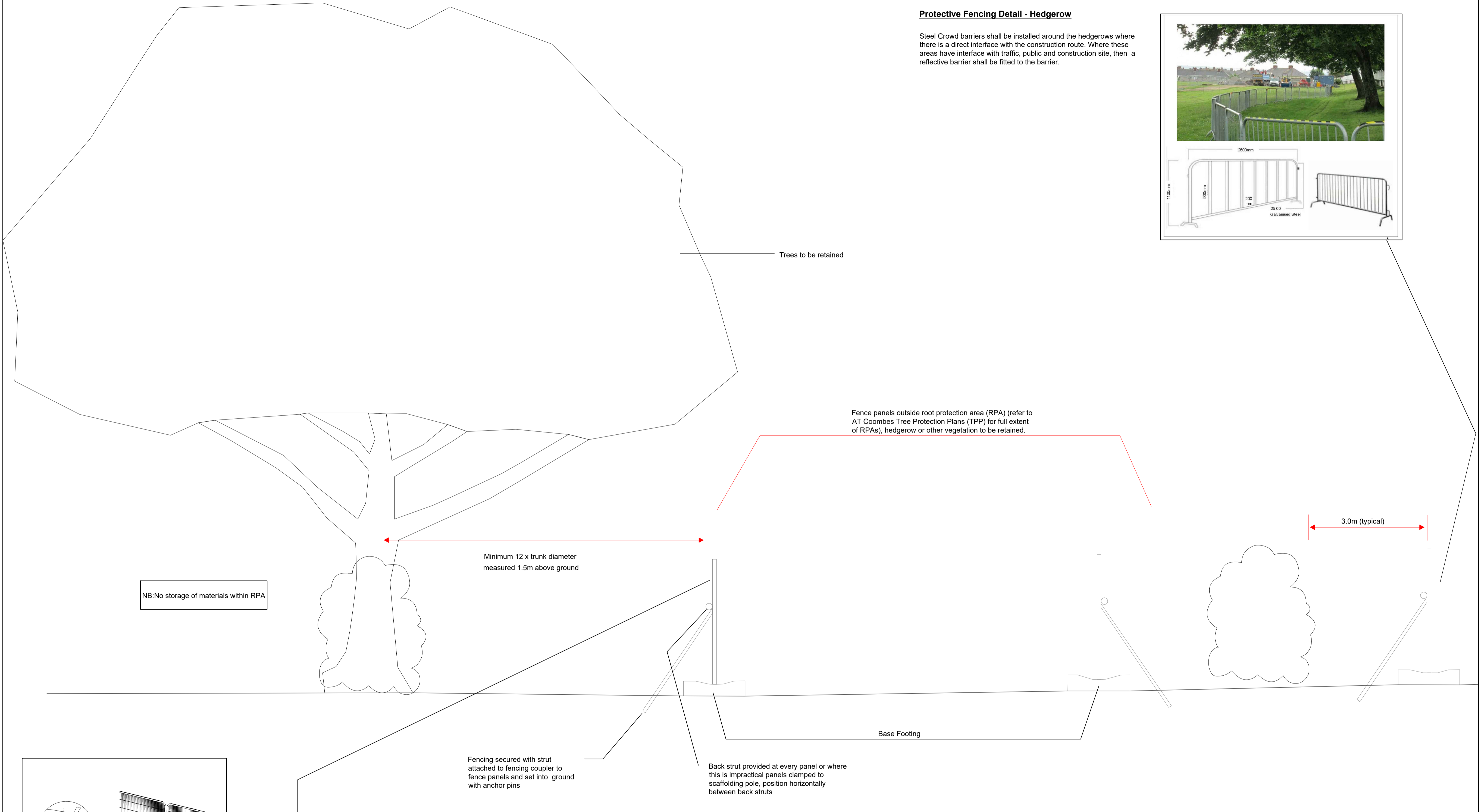

Protective Fencing Detail - Hedgerow

Steel Crowd barriers shall be installed around the hedgerows where there is a direct interface with the construction route. Where these areas have interface with traffic, public and construction site, then a reflective barrier shall be fitted to the barrier.

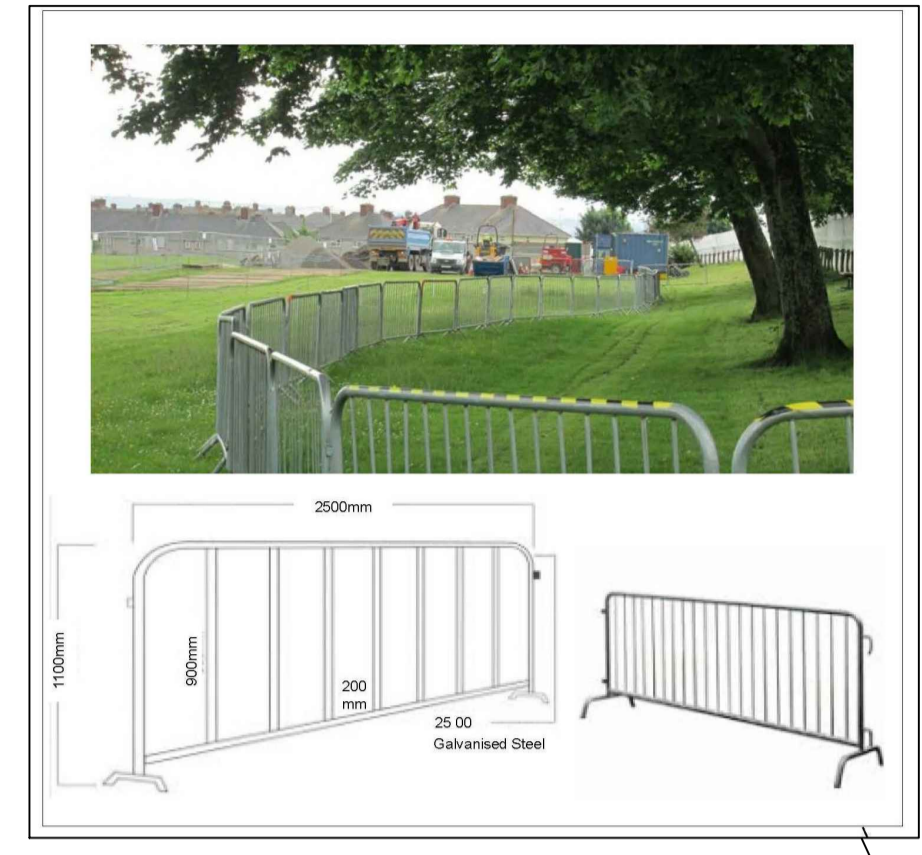

Fence panels outside root protection area (RPA) (refer to AT Coombes Tree Protection Plans (TPP) for full extent of RPAs), hedgerow or other vegetation to be retained.

Minimum 12 x trunk diameter measured 1.5m above ground

3.0m (typical)

Base Footing

Fencing secured with strut attached to fencing coupler to fence panels and set into ground with anchor pins

Back strut provided at every panel or where this is impractical panels clamped to scaffolding pole, position horizontally between back struts

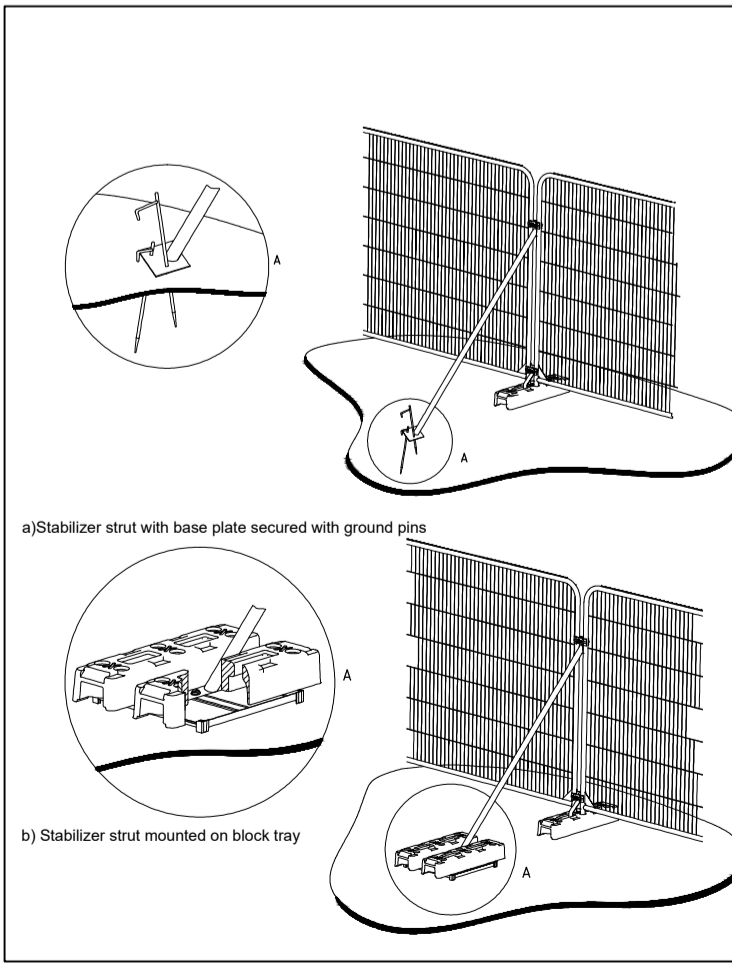

Protective Fencing Detail - Tree

The fence panels should be joined together using a minimum of two anti-tamper couplers installed so they can be removed from the inside of the fence. The distance between couplers should be at least 1m and be uniform throughout the fence. Panels should be supported on the inner side by stabilizer struts which should normally be attached to a base plate and secured with ground pins. Where the fence will be erected on hard surfacing or it is otherwise unfeasible to use ground pins the struts should be mounted on a block tray.

NOTES

1. This drawing is to be read in conjunction with all other drawings and specifications.
2. Do not scale off this drawing. Written dimensions to be taken only.
3. Any discrepancies found between this drawing and other drawings and specifications in the construction documents must be referred to the Landscape Architect prior to work commencing.
4. This drawing must not be copied in whole or in part without prior written consent of Optimised Environments Ltd.

DRAWING INFORMATION BASED UPON

Emapsite: © Crown copyright and database rights 2019 Ordnance Survey 0100031673.
OS OpenData: Contains OS data © Crown copyright and database right (2019).
Google Earth: Please show the attribution statement shown on the Google map or image that you are using.
Topographical Survey: Please reference surveyor's survey.

CDM INFORMATION

KEY PLAN

Issue	Revision	Initial	Date
02	SPR comments.	jt	27.01.2022
01	Annotation amended.	rt	10.01.22
00	Draft Issue for comments	rt	16.12.21

open
optimised environments
 optimised environments ltd
 EDINBURGH 2nd Floor | Quaternite Two | 2 Lister Square | Edinburgh | EH3 9JL
 0131 221 9820 | optimisedenvironments.com
 LONDON 407111 Finsbury Street | London | EC2A 3BB
 0203 984 4022 | optimisedenvironments.com
 MANCHESTER 13 Swan Street | Manchester | M4 5JZ
 0161 696 7500 | optimisedenvironments.com

Client
ScottishPower Renewables

Project
East Anglia THREE Offshore Windfarm

Drawing Title
**APPENDIX 5
 Typical Details for
 Tree & Hedgerow Protective Fencing**

Scale Bar North

Scale: **1:20@A1** Date: **December 2021**

By: **rt** Status: **INFORMATION**

Checked: **jd** Approved: **lt**

Drawing Number
EA3-LDC-CNS-DRG-IBR-000008 Rev **02**